

**Installation and Finishing Manual
for
Polyurethane (PUR) Core
Structural Insulating Panels**

THE MURUS COMPANY, INC.

P.O. BOX 220, 3234 ROUTE 549
MANSFIELD, PENNSYLVANIA, USA 16933
Toll free: 800-626-8787 Phone: 570-549-2100
Fax: 570-549-2101
E-mail: info@murus.com • www.murus.com

This item has been electronically signed and sealed by Gary Hartman on 6/10/2021 using a SHA authentication code.

Printed copies of this document are not considered signed and sealed and the SHA authentication code must be verified on any electronic copies.

Copyright 2017, 2016, 2008, 2007, 2006, 2003, 1998 by The Murus Company, Inc.
All rights reserved. This publication may not be reprinted
or reproduced, in whole or in part, without the written
permission of The Murus Company, Inc..

TABLE OF CONTENTS

MANUAL UTILIZATION	5
PRODUCT DESCRIPTION AND MATERIALS	5
HANDLING OF STRUCTURAL INSULATING PANELS	7
Building Site	7
Unloading	7
Safety	8
Protecting SIPs	9
Extended Storage	9
PREPARING FOR CONSTRUCTION	10
Technical Information	10
Technical Drawings	10
Special Tools	10
The Murus Panel Router	10
Cam-locks	11
Fasteners	11
2x Inlet Plates and Nailers	13
Factory Pre-Cutting of Panels	13
On-Site Cutting of Panels	13
On-Site Routing	13
FOUNDATION SYSTEMS AND FLOOR FRAMING	14
Foundation Systems	14
Contact with Masonry	14
Sill Details	15
First Floor Systems	16
Wrapped Floor System	17
Platform Framed Floor System	18
Rim Joist Header Method	19
INSTALLING STRUCTURAL INSULATING PANELS	20
Full Bearing Surface	20
Joining Panels	20
Sealing with Spray Foam	21
Construction Adhesives and Caulking Sealants	21
Plates, Inlet Nailers, Posts, Headers, and Splines	22
Bottom Inlet Nailer	22
Top Inlet Nailer	23
Load Bearing Top Plate	23
Load Bearing Top Plate Header	23
Second Floor Systems	24

Platform Framed Second Floor	25
Girder/Beam Housing	26
Spline Joints	27
Corner Connections	28
Roof Framing Systems	30
Stick Framed Roof	30
Purlin Roof System	31
Purlin Bearing Housing	33
Common Rafter Roof System	34
Roof Panel Installation on Common Rafter System.....	34
Rafter Bearing Housing	35
Cantilevering Roof SIPs	36
Eave Details	36
Rake Details	38
Roof Peak or Ridge Details	39
Installing Nailers in Rough Openings	41
Installing Headers in Rough Openings	42
Installing Doors, Windows and Skylights	44
WIRING	45
Accessing Electrical Receptacles	45
Accessing Light Switches	49
Establishing Wiring Access to the Second and Third Floor	49
Wiring in Roof Panels	49
Wiring Around Doors and Windows	51
FINISHING DETAILS	53
Continuous Nailing Surface	53
Vapor Barriers	53
House Wraps	53
Air Infiltration	53
Air Exchangers	53
Sealing the Panel Seams	54
Drywall and Other Interior Finishes	54
Roofing	54
Shingles	55
Venting the Roof	55
Siding and Exterior Finishes	55
Masonry Finishes	56
Interior Finish: Trim, Cabinets, Etc.	57
APPENDIX A: STRUCTURAL INSULATING PANEL TECHNICAL GLOSSARY	58

MANUAL UTILIZATION

This manual is intended to provide design and building professionals with information and guidelines for the proper installation of Murus Structural Insulating Panels. The Murus Company, Inc. personnel are available at 800-626-8787 from 8:00 a.m. to 5:00 p.m. Eastern Time, Monday through Friday, for further explanation and clarification. Please use us as a resource. We value your expertise and welcome your suggestions.

Murus drawings and specifications must be adhered to in all situations. Murus drawings meet the requirements of the latest edition of the IRC (International Residential Code) for one- and two-family dwellings (please contact Murus for other design considerations). Murus cannot assure that all codes having jurisdiction in a given locality are met. Therefore, it is the customer's responsibility to verify requirements with local building officials. Do not alter any part of a Murus drawing without consulting Murus.

Project Drawings: Any deviation from project drawings or details thereof should be reviewed and approved by the Design Professional and/or Professional Engineer for the project. All local, state, and national fire and building codes must be adhered to.

Important Note: This manual is intended to be utilized by building professionals with experience in residential and/or light commercial construction. The details contained herein are generic in nature and are not project-specific. Murus will not be responsible for the improper use of this manual or details contained herein and/or for drawings or specifications not prepared by Murus.

PRODUCT DESCRIPTION AND MATERIALS

The standard Structural Insulating Panel (SIP) offered by Murus is a foam-core, or "sandwich" panel, and consists of three layers of material: two exterior skins of $7/16$ " thick oriented strand board (OSB), and either a $3\ 5/8$ ", $4\ 5/8$ ", or $5\ 5/8$ " thick urethane foam core (See Figure 1). The urethane foam core is a combination of an isocyanate and a polyol/catalyst blend. These two components are mixed and uniformly dispersed into a mold where the expanding foam bonds to the OSB skins while curing in a press. (Refer to Murus product specification sheet for additional information.)

Murus SIPs feature a patented ABS plastic, glass reinforced cam-lock on the vertical edges of the panel. The cam-lock is centered in the foam along the panel edge. During manufacturing, the liquid foam is dispersed such that it forms around the cam-lock. The cam-lock has flanges to aid in retaining it in the foam. Located every 2' on the vertical (long) edge of the panel, the cam-locks have an eccentric locking action that pulls the panels together snugly. The cam-lock is used to install panels **and is not a structural component - only a facilitator in installation.**

The vertical foam edges of Murus SIPs are molded into a tongue-and-groove profile. This profile, in conjunction with the cam-lock, ensures alignment and tight foam-to-foam fit of the panels.

Standard Murus OSB SIPs are 4' wide, available in 4', 6', 8', 9', 10', 12', 14', 16', 18', 20', 22', and 24' lengths, in 4⁵/₈", 5⁵/₈", and 6⁵/₈" nominal thicknesses.

Figure 1. The Murus Structural Insulating Panel available lengths and chase height options

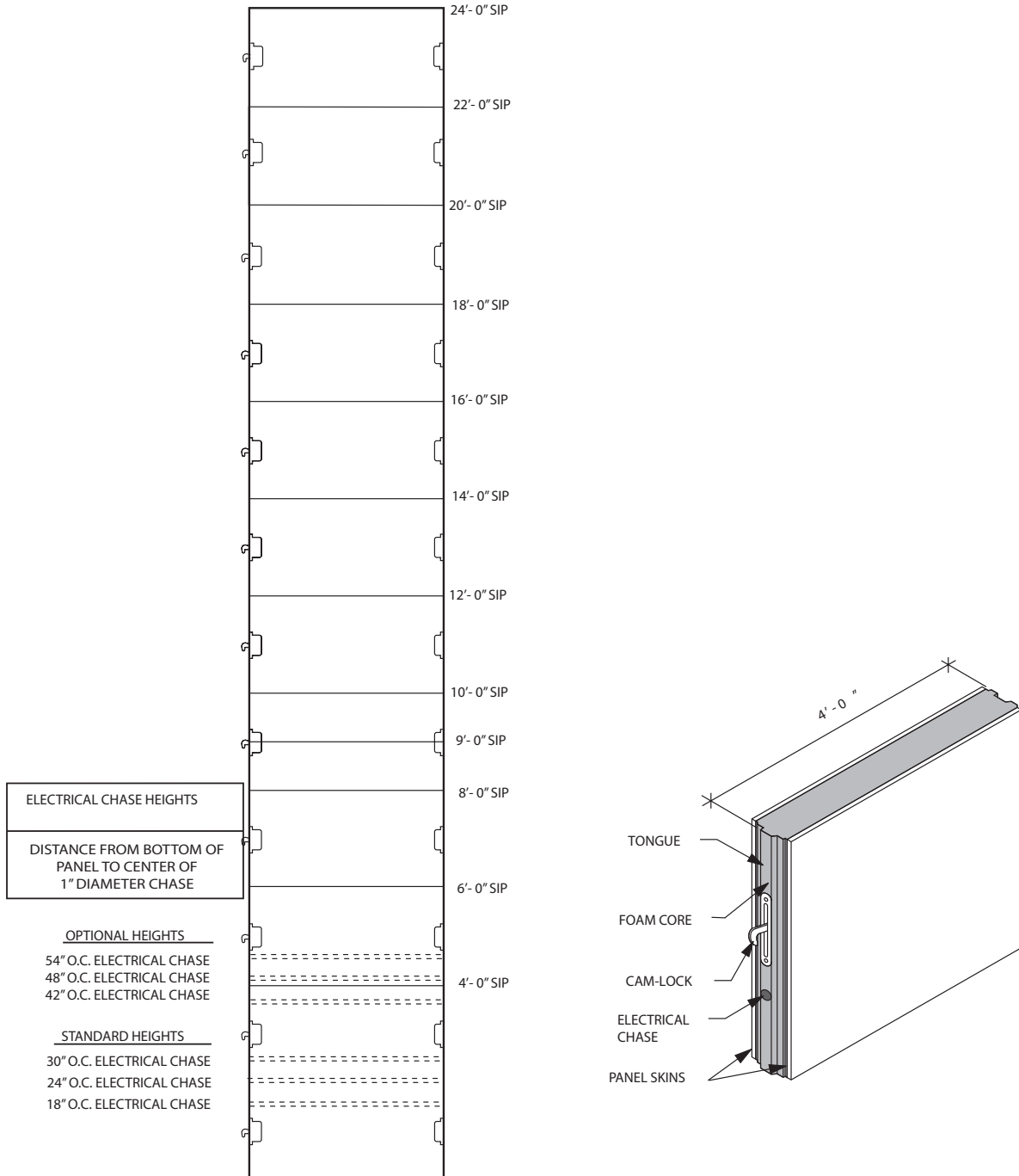

HANDLING OF STRUCTURAL INSULATING PANELS

Building Site:

The building site should be relatively level, free of debris, and accessible to a 70' long tractor-trailer truck. Allowances must be made for truck maneuverability and level stacking of panels close to the structure.

Unloading:

Unloading of panels is best accomplished with an all-terrain forklift with 42' or 48' forks. Refer to Tables 1A, 1B, and 1C for weights of Murus Polyurethane SIPs.

Table 1A. Individual and Bundle Panel Weights for **4-5/8"** OSB-2100/PUR Panels
Weight units are in pounds and are approximate.

Panel Size (Feet)	Individual Panel Weights (Pounds)	Bundle Panel Weights (10 Panels) (Pounds)
4 x 8	126	1260
4 x 9	142	1420
4 x 10	158	1580
4 x 12	190	1900
4 x 14	221	2210
4 x 16	253	2530
4 x 18	284	2840
4 x 20	316	3160
4 x 22	348	3480
4 x 24	379	3790

Table 1B. Individual and Bundle Panel Weights for **5-5/8"** OSB-2100/PUR Panels
Weight units are in pounds and are approximate.

Panel Size (Feet)	Individual Panel Weights (Pounds)	Bundle Panel Weights (8 Panels) (Pounds)
4 x 8	133	1064
4 x 9	149	1192
4 x 10	166	1328
4 x 12	199	1592
4 x 14	232	1856
4 x 16	266	2128
4 x 18	299	2392
4 x 20	332	2656
4 x 22	365	2920
4 x 24	398	3184

Table 1C. Individual and Bundle Panel Weights for **6-5/8"** OSB-2100/PUR Panels
Weight units are in pounds and are approximate.

Panel Size (Feet)	Individual Panel Weights (Pounds)	Bundle Panel Weights (7 Panels) (Pounds)
4 x 8	139	973
4 x 9	157	1099
4 x 10	174	1218
4 x 12	209	1463
4 x 14	244	1708
4 x 16	278	1946
4 x 18	313	2191
4 x 20	348	2436
4 x 22	383	2681
4 x 24	418	2926

Safety:

Panels can be heavy, so for safer and faster installation, it is recommended that a crane be used when handling larger panels. Always wear OSHA approved eye, ear, and head protection gear when routing, cutting, or installing panels.

Protecting SIPs:

Murus SIPs are manufactured with APA (American Plywood Association) rated Exposure-1 or equivalent OSB skins, and are not designed to be exposed to the weather beyond normal building/construction time. It is recommended that Murus SIPs be covered before and after construction to avoid damage caused from exposure to the elements.

Murus SIPs are delivered to the building site in bundles wrapped in a polyethylene covering. Off-load the panels onto level risers which are tall enough to create an air flow beneath the bundle. This will help inhibit ground moisture from condensing on the underside of the bundle and polyethylene wrap. Insure that the bundles remain tightly wrapped until panels are installed, and re-cover partially used bundles.

Since Murus SIPs are not intended to be left exposed to the weather, once they are installed it is imperative to immediately apply a code-approved, weatherproof roofing, siding, and trim, so that the SIPs are completely covered and protected from rain, snow, high moisture, and ultraviolet light. For more information, refer to the Roofing and Siding sections of this guide on Pages 54, 55, and 56.

Extended Storage:

For extended storage of SIPs, Murus recommends placing the wrapped bundles of panels in a fully enclosed structure that will provide protection from exposure to wind, rain, moisture, and ultraviolet light. Be sure the storage surface or storage area of the structure is level and sound. Murus recommends limiting stacks to two (2) bundles high, with risers installed under and between the bundles, spaced no more than 2' apart (see Figure 2 below). If an enclosed structure is not available, the bundles should remain in their original packaging and be covered with durable, waterproof tarps.

Figure 2. Proper Panel Bundle Storage

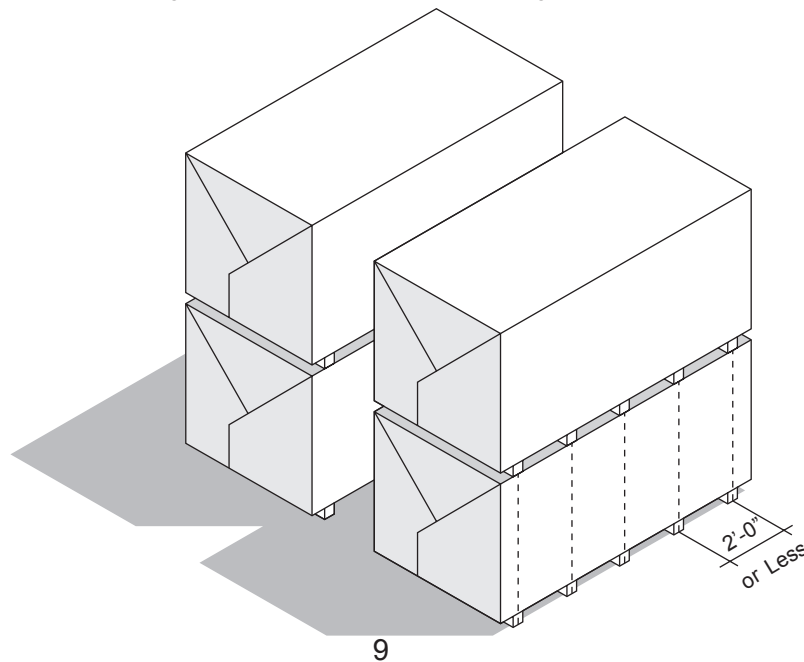

PREPARING FOR CONSTRUCTION

Technical Information:

This manual is provided to facilitate installation of Murus SIPs. Read the manual, paying particular attention to construction techniques, details, notes, etc., that may pertain to your project. Doing so will help insure a smooth panel installation.

Technical Drawings:

Become familiar with the panel layout and technical drawings. Panel drawings are used to present the four aspects of the panel system: the individual panels, their dimensions, how they fit into the scheme of the building, and connection and installation details.

A typical set of Murus panel drawings includes exterior wall elevations, roof plan, special features such as eave, rake, and connection details, overall dimensions, and string-line dimensions. Rough opening dimensions are labeled and used to reference window and door sizes, locations, etc..

Note: Technical drawings should be properly prepared and engineered by a qualified design professional.

Special Tools:

Cutting and installing SIPs requires special tools. These are: a 16" circular saw (with carbide-tip blade), a standard circular saw (cut one side of the panel, then flip the panel over and complete the cut through the other side), or a standard circular saw with a bar and chain attachment; a panel router, and cam-lock wrenches. The panel router is available for purchase or rental from Murus while the cam-lock wrenches are supplied with each first-time order, or on request.

The Murus Panel Router

The Murus panel router (see Figure 3, Page 11) is a specially adapted tool for removing the foam core edges of Murus SIPs to accommodate inlet plates and nailers. The Murus panel router should not be confused with a traditional hand-held router.

Figure 3. The Murus Panel Router

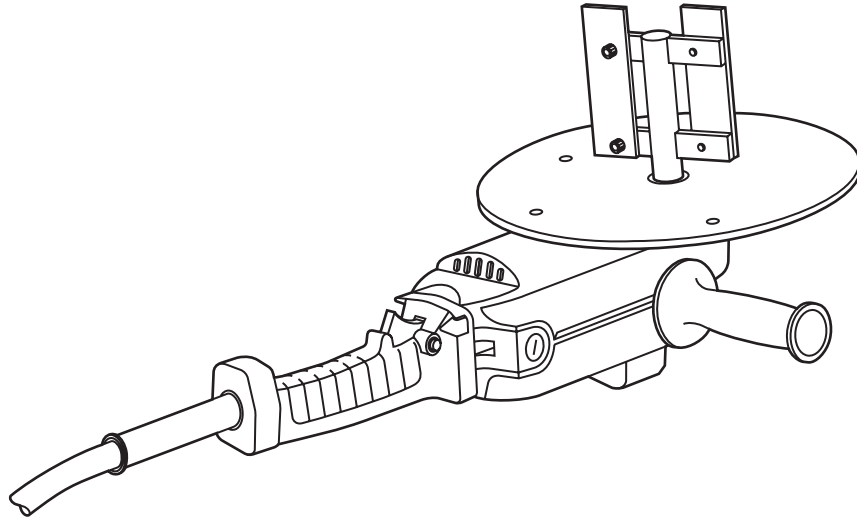

Cam-locks:

The Cam-lock is designed to aid in the installation of panels by drawing the tongue and groove edges together once the panels are within $\frac{3}{8}$ " of one another. If panels are misaligned when the cam-lock is engaged, or if excessive force is applied, it is possible to break the cam-lock mechanism. Located in the tongue-and-groove edges of the panel, the eccentric action of the cam is used to align the edges of the panels and tightly draw them together. The cam-lock is turned in a counterclockwise direction, utilizing the cam wrench, until the cam clicks, indicating that the eccentric action has now locked the cam arm in place.

NOTE: Forcing the cam-lock in the opposite (clockwise) direction or turning it past the locked position may strip the action and/or damage the internal parts.

Fasteners:

Typical fasteners used in SIP construction include: 1) The cam-lock, used to connect the tongue-and-groove edges of the panels (**this is not a structural component - only a facilitator during installation**); 2) 8d or 16d coated ring shank nails; 3) 6", 7", 8", 9", 10", 12", or 14" corrosion-resistant ring shank nails, or corrosion-resistant panel screws; 4) 3" and 3½" coated screws, or other approved material fastener for use with pressure-treated wood.

Table 2. Fastening Schedule

*WALL PANEL CONNECTIONS		
APPLICATION	FASTENER	SPACING
Bottom inlet nailer to pressure treated sill plate	3" coated screws	6" O.C. staggered or offset
Top plate to top inlet nailer	16d coated nails	6" O.C. staggered or offset
Bottom inlet nailer to platform floor system	3 1/2" coated screws	6" O.C. staggered or offset
Bottom inlet nailer to wrapped floor system	3" coated screws	6" O.C. staggered or offset
OSB skins to top and bottom inlet nailers	8d coated corrosion-resistant ring shank nails	4" - 6" O.C.
OSB skins to posts and headers	8d coated corrosion-resistant ring shank nails	4" - 6" O.C.
OSB skins to inlet nailers	8d coated corrosion-resistant ring shank nails	6" - 8" O.C.
OSB skins to plywood keysplines	8d coated corrosion-resistant ring shank nails	4" - 6" O.C.
SIP to rim joist and structural support members	Panel screws or panel nails	12" - 16" O.C.
Wall corner connections	Panel screws or panel nails	12" - 16" O.C.

*ROOF PANEL CONNECTIONS		
APPLICATION	FASTENER	SPACING
SIP-to-roof support member i.e. rafter, purlin, joist		
16" - 24" O.C. 1 1/2" members	Panel screws	18" - 24" O.C.
2' - 4' O.C. members	Panel screws or panel nails	16" - 24" O.C.
4' - 6' O.C. members	Panel screws or panel nails	12" - 16" O.C.
6' - 8' O.C. members	Panel screws or panel nails	8" - 12" O.C.
Roof panel to wall panel	Panel screws or panel nails	4" - 16" O.C.
OSB skins to plywood keysplines	8d coated corrosion-resistant ring shank nails	4" - 6" O.C.

***NOTE:** These fastening schedules are intended for use in normal wind and loading conditions. High load, high wind, and seismic conditions may require additional fastening. **Always refer to the fastener schedule on the Panel Layout drawings for the panel fastener size and spacing for your project.** All fastener spacing should be reviewed by a design professional. Murus recommends the use of coated/corrosion-resistant fasteners wherever the fastener may be directly or indirectly exposed or subjected to moisture.

2X Inlet Plates and Nailers:

All plates and nailers are to be kiln-dried to a moisture content of 19% or less, SPF #2 grade or better, unless a higher grade is specified in the panel layout or project drawings.

Factory Pre-Cutting of Panels:

Pre-cutting of panels at the Murus manufacturing facility saves installation time and greatly reduces on-site scrap and disposal requirements. Wall and roof panels are cut to size utilizing Murus's state-of-the-art computerized CNC equipment. Factory pre-cutting includes cutting of rough openings for windows and doors, routing to remove foam where nailers, inlet plates, posts, and headers are to be installed, and cutting and trimming panel edges where needed. Installation of nailers, inlet plates, posts, and headers is done on site.

On-Site Cutting of Panels:

NOTE: *Power tools should only be operated by qualified individuals. Special care and safety precautions should always be used when operating power tools.*

Cutting panels on the jobsite requires an elevated sturdy work station where panels can easily and safely be handled, cut, and routed. Cutting the panel is done with either a 16" hand-held circular saw or a beam cutting attachment for a circular saw in one pass, or with a 7¼" circular saw, from both sides.

NOTE: Angled cuts may require cutting from both sides depending on the depth of the cut required. When cutting rough openings, cut to the line, not past. Finish cutting the inside corners of the bottom skin and foam with a hand saw.

On-Site Routing:

Installation of nailers, inlet plates, posts, and headers require the removal of the foam core from between the panel skins. This process is referred to as routing.

Routing is best accomplished with a Murus panel router, but other hand and power tools may be used. If using other tools, you must pay attention not to over-rout the depth.

Routing should always be done from the exterior side of the SIP so that an even, consistent channel is cut from panel to panel.

When routing inside corners such as a rough opening, a small hand saw or knife may be used to square and remove the foam that the router bit cannot reach. This squaring of the inside corners ensures that the inlet nailers and plates fit properly.

FOUNDATION SYSTEMS AND FLOOR FRAMING

Foundation Systems:

Murus in no manner warrants or promotes the use of any particular foundation system. However, Murus recommends the use of the following guidelines when planning or specifying foundation systems:

The foundation systems used with SIP construction are similar to any acceptable foundation used in typical residential or commercial construction, given the proper site preparation, soil bearing capacity, installation, etc.

The outside dimensions of the SIPs should match the outside dimensions of the slab or foundation walls so that the SIPs will ultimately bear entirely on the foundation, and so that the siding will extend slightly past the foundation walls or slab.

Slight inaccuracies in the foundation wall or slab dimensions should be corrected when setting the sill plates. Sill plates must be cut to the correct dimensions, set level and square, and bear completely on the foundation wall or slab.

All foundation systems should be reviewed, and/or designed, by a professional engineer to insure structural adequacy. Special attention should be given to axial/compressive point loading.

Contact with Masonry:

As with any untreated wood product, it is imperative to prevent contact between SIPs and masonry. A pressure-treated plate must be located between a SIP and any masonry or foundation work.

Sill Details:

Figures 4A, below, and 4B, Page 16 illustrate typical sill connection, floor framing, and panel connections at the foundation wall. The sill connection serves two major functions. First, it serves to resist lateral loads encountered from wind and seismic loading, allowing the panels to react with a diaphragm action. Secondly, it resists uplift forces induced by wind loads on the walls and roof(s). The sill plate is typically secured to the foundation with either strapping or anchor bolts, depending on local code requirements. Murus recommends the use of insect shields and foam sill seal between all masonry and sill plates. Figure 4C, Page 16 illustrates the panel connection typically used with a concrete slab.

Figure 4A. Typical Sill, Bottom Inlet Plate and Wrapped Floor Connection on a Foundation Wall

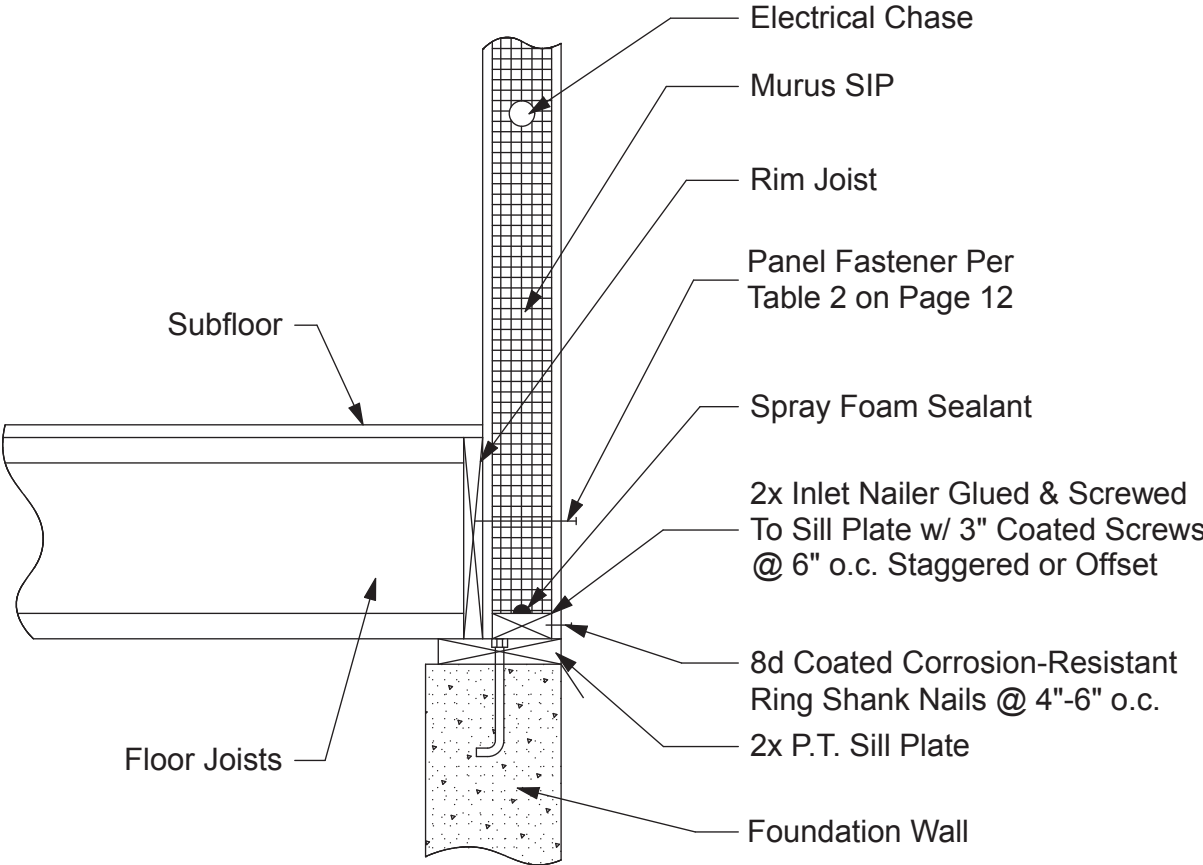

Figure 4B. Typical Sill, Plate, and Platform Floor Connection on a Foundation Wall

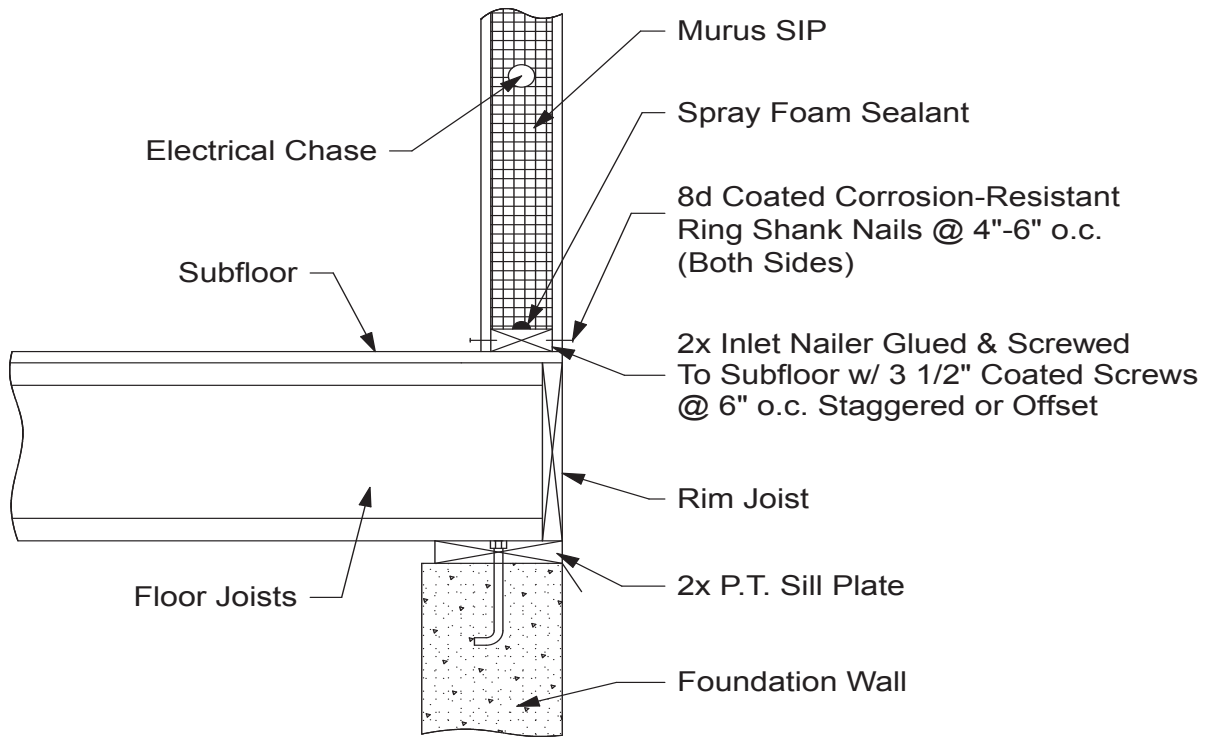
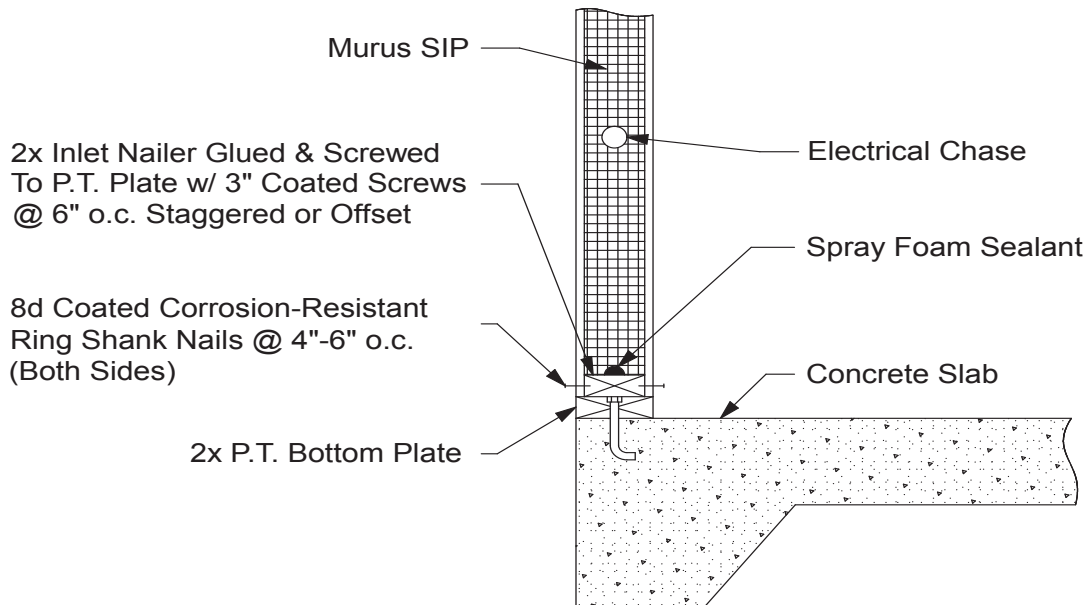

Figure 4C. Typical Sill and Plate Connection on a Slab



First Floor Systems:

Various floor framing systems may be used according to locally accepted practices and/or manufacturers' recommendations. These include conventional lumber or "stick" joist systems, engineered wood products such as floor trusses, wood "I" beams, and glue laminated materials, or any combination of the above materials.

Wrapped Floor System:

Figure 5A below illustrates the location of all floor framing members on the interior of the wall SIPs. The wrapped floor system method provides the best continuity of insulation and has the added benefit of creating a stronger tie between the wall and floor systems.

Figure 5A. Typical Wall Section with Wrapped Floor Systems

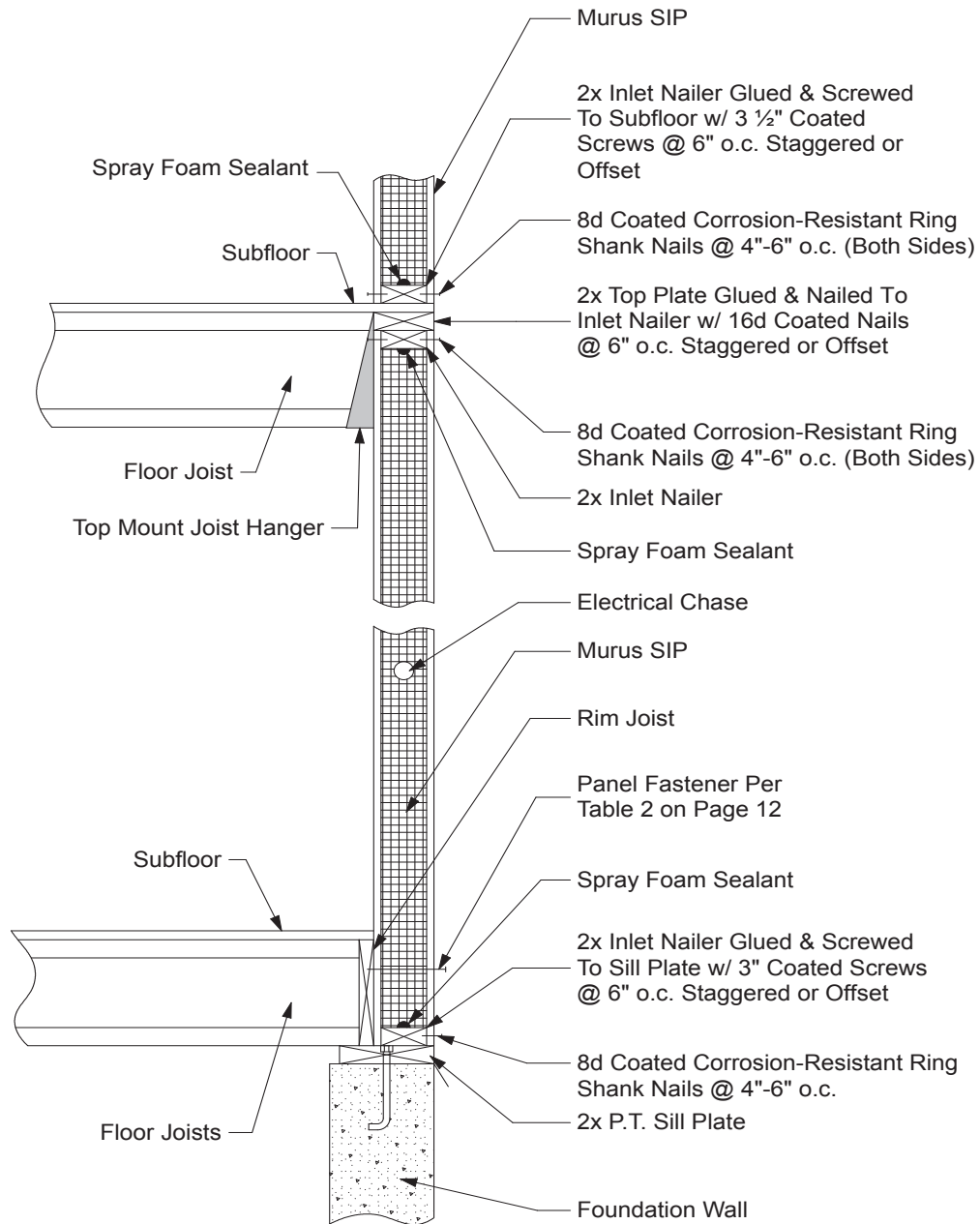

Platform Framed Floor System:

Figure 5B illustrates platform framed floor systems which are located beneath or intermittent to the SIP wall(s) with the SIP bearing on the floor system.

Figure 5B. Typical Wall Section with Platform Framed Floor Systems

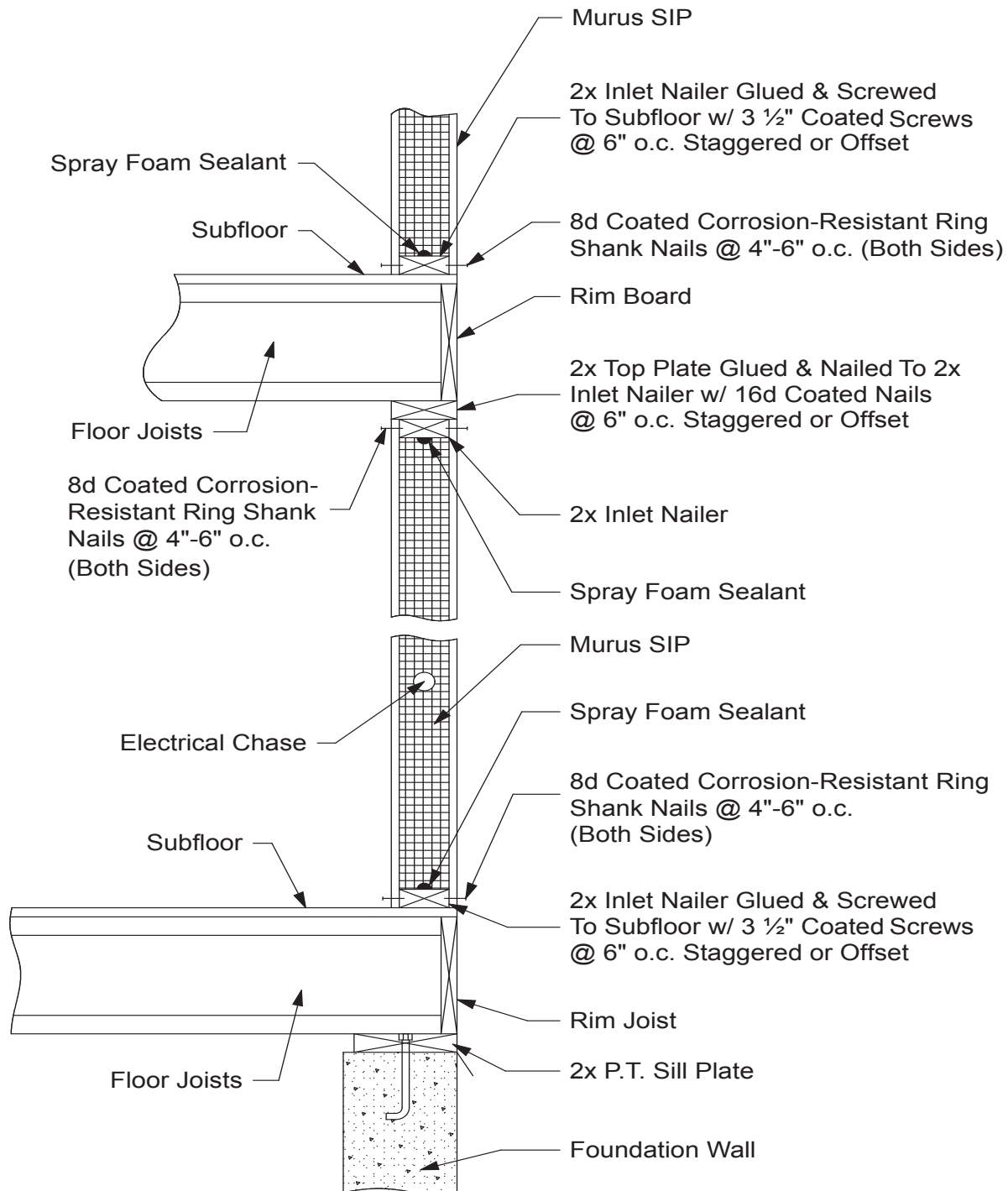

Rim Joist Header Method:

Some Murus SIP installations require headers over window and door openings. An alternative construction method for two stories or more is the placement of headers within the floor system. This method is often less labor-intensive than conventional framing methods, and may be recommended as an alternative to placement of headers within the wall panel. Removing less material from the SIP provides the added benefit of increased insulation value in the wall. The Rim Joist Header Method utilizes the rim joist in conjunction with additional reinforcing materials, depending on the load-carrying requirements (see Figure 6).

Figure 6. Typical Wall Section with Platform Framed Floor Systems with a Rim Joist Header

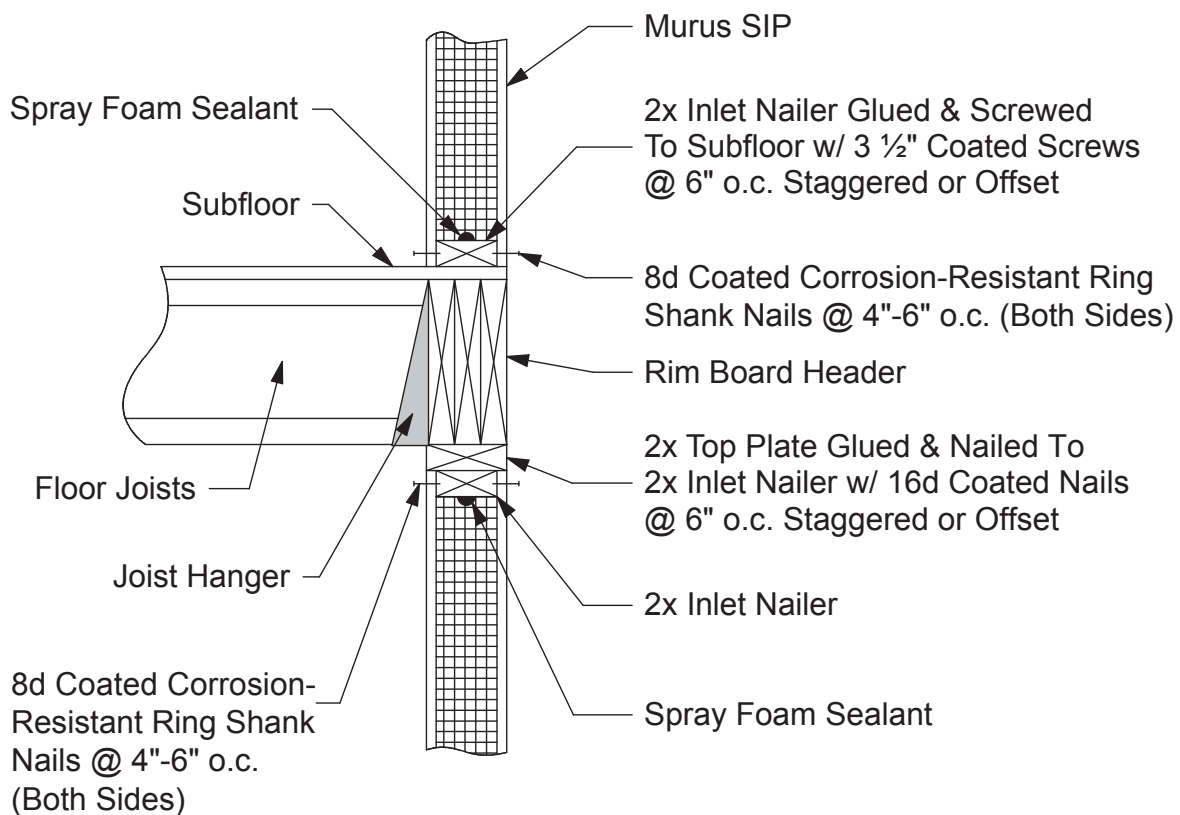

INSTALLING STRUCTURAL INSULATING PANELS

Full Bearing Surface:

Murus SIP walls must be installed level and plumb. Hence, it is essential that the SIP be installed on a level, continuously supported bearing surface such that the entire SIP (both skins) bears on this surface. If the bearing surface is not level, then either, 1) the bearing surface must be made level, or 2) the bottom of the SIP must be cut to conform to the bearing surface, ensuring that the SIP is vertical, plumb, and fully bearing.

Joining Panels:

A variety of methods can be used to join panels together. First and foremost is the **cam-lock**, tongue-and-groove panel seam. With the cam-lock system, there is both a male and a female component. The male half of the lock houses the eccentric cam action and hook while the female half houses the connection pin. Extremely tight seams are achieved with the cam-lock system, in conjunction with the spray foam sealant. A very liberal bead of spray foam sealant is applied to the grooved panel edge before the adjoining panel is pushed tight to the fixed panel. After aligning the two panels, the hex head cam wrench is inserted into a pre-drilled hole in the OSB (usually on the exterior side), engaging the cam turning gear. The wrench is then turned counterclockwise approximately 90 degrees until the cam arm locks. At this point it is still possible to unlock the cam by reversing the wrench.

A second method of adjoining panels is referred to as a **splined** joint. Dimensional lumber or keysplines are inserted and fastened between the OSB skins where the foam has been routed out. Splined seams are used to secure adjoining panels where the tongue-and-groove cam-lock connection is not available, or in instances where structural reinforcement is required, i.e., corners, ridges, post locations, etc. For details, refer to Figure 10A through 10E on Pages 27 and 28. Spray foam is liberally applied into the foam cavity prior to inserting the post, nailer, or spline. Once the member has been inserted into the cavity, it is fastened to the OSB skins with 8d coated corrosion-resistant ring shank nails from both sides. Please refer to the Fastening Schedule on Page 12.

Sealing with Spray Foam Sealant:

Sealing Murus SIPs with spray foam sealant is a very critical installation step, and great care should be taken to properly complete this portion of the installation. The spray foam sealant is used to eliminate or prevent the infiltration of air and moisture through the panel joints and connections. The spray foam sealant also creates a bond between the two surfaces (foam-to-foam or foam-to-wood), resulting in a stronger connection. Failure to properly seal panel joints and connections may affect the panel warranty.

All occurrences of foam-to-foam contact, such as the tongue-and-groove panel edges, are sealed with liberal amounts of spray foam sealant as the panels are installed. All occurrences of foam-to-wood contact, such as plates, nailers, etc., are also sealed with liberal amounts of spray foam sealant as the members are installed. **NOTE:** In colder weather, it is important to keep the spray foam from freezing. Keep spray foam warm by storing in a heated location. Spray foam works best at temperatures above 50° F.

After the panels have been installed, a bead of spray foam sealant is applied in the space between the exterior OSB skins, as well as in the cam-lock holes. As the foam cures, it will swell and protrude from the panel surface. This “extra” foam should not be removed until the exterior finishes (roofing and siding) are being applied. This will help to protect the underlying foam from UV exposure and possible breakdown. To remove the extra foam, simply scrape it away from the panel surface using a taping knife or similar scraping device.

Spray foam sealant is applied around windows and doors to prevent air infiltration and moisture transfer. It is strongly recommended that a minimally-expanding spray foam be used to fill the cavity with 3 or more small applications until the cavity is filled. **IMPORTANT:** Allow each application of foam to cure (12 - 24 hours) before applying the next layer. This foaming procedure will help reduce the possibility of binding and/or bowing of the jambs due to the expansion of the foam. For more information see **Installing Doors, Windows, and Skylights** on Page 44.

Spray foam sealant, available in hand-held canisters with an applicator attachment, is provided by the case with most panel orders. Closely follow precautions and directions on the container for safe handling and to optimize its use.

Construction Adhesives and Caulking Sealants:

Construction adhesives are used where wood members, such as nailers, plates, etc., come into contact with another wood member. Adhesives provide the best bond and seal between wood products, whereas spray foam provides the best bond and seal between foam and wood products.

To further seal panel seams, caulking sealants (Murus recommends siliconized caulk for durability) can be used on the interior of the structure wherever panel seams are accessible. This further aids in reducing moisture and vapor transmission.

Plates, Inlet Nailers, Posts, Headers, and Splines:

The installation of these materials, in the areas where the foam has been routed to allow for their insertion, is preceded by applying a liberal amount of spray foam sealant into the recess. Nailing and fastening of these materials to the OSB skins is accomplished with coated ring shank nails, in accordance with Table 2: Fastening Schedule on Page 12. See Figure 7A below for inlet installation detail.

Figure 7A. Typical Inlet Nailer Detail

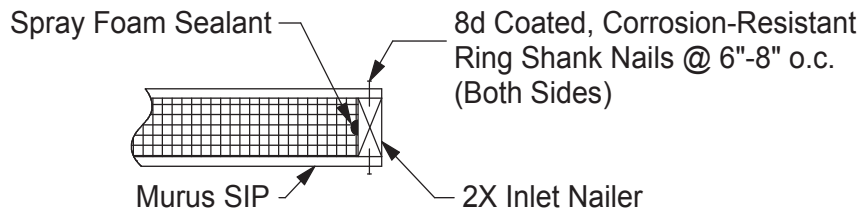

Sills, plates, inlets, posts, headers, and splines serve the important structural functions of resisting uplift, racking and flexure loading. The craft and care given to this installation is important. See Figures 5A, 5B, and 6 on Pages 17, 18, and 19, as well as the following descriptions and illustrations.

Bottom Inlet Nailer:

A 2X bottom inlet plate must be located in the bottom of all wall SIPs. With a wrapped first floor system, this plate is securely fastened to the pressure-treated sill plate with 3" coated screws located 6" on center in a staggered or offset pattern and with construction adhesive between the plates. For platform framing or second floor applications, use 3 1/2" coated screws fastened through the subfloor and into the rim board and floor joists.

The bottom of the wall SIP must be routed to remove the foam core to a depth of 1 1/2", such that the OSB skins of the SIP will bear fully on the pressure-treated sill plate or subfloor. Once the SIP is placed over the inlet plate, the OSB skins are nailed to the inlet plate with 8d coated ring shank nails 4" - 6" on center from both sides (from the exterior only in the case of a "wrapped" deck). Liberal amounts of spray foam must be applied to the inlet plate prior to installing the SIP.

When utilizing the wrapped first floor system (Figure 5A, Page 17), the bottom of the SIP should also be nailed or screwed into the rim joist. Install the fasteners near the top of the rim joist at 6" - 8" on center. Please refer to the Fastening Schedule on Page 12, and Figure 4A on Page 15.

IMPORTANT: Do not fully set these fasteners into the rim board until the tops of the panels are plumb and fastened to the second floor or roof system.

Top Inlet Nailer:

Typically, a wall SIP will have a 2X (width is dependent on the thickness of the foam core) top inlet nailer installed so that the vertical panel-to-panel joints are offset from the inlet nailer butt joints. The inlet nailer is installed in a 1 1/2" deep rout in the foam core at the top of the panel. During installation of the inlet nailer, spray foam is liberally applied between the foam core and wood nailer. The inlet nailer is attached to the SIP by nailing through both OSB skins with 8d coated corrosion-resistant ring shank nails at 4" - 6" on center, from both sides (See figure 7B). **NOTE:** If the inlet nailer is not a continuous 2X which spans the full length of the wall, it is very important to make sure that the butt joints of the inlet nailers are offset from the vertical panel-to-panel joints.

Load Bearing Top Plate:

The top plate is located directly on top of the top inlet nailer and provides bearing for 1) joist hangers and subflooring, 2) trussed rafters, and 3) second floor wall SIPs. The top plate is usually 2X material ripped to the width of the panel (depends on the thickness of panel being used), so that it bears fully on both inside and outside skins of the panel. Construction adhesive is applied between the inlet plate and the top plate. The top plate is then nailed to the inlet plate with 16d coated nails at 6" on center in a staggered or offset pattern (see Figure 7B).

Figure 7B. Load Bearing Top Plate Connection Detail

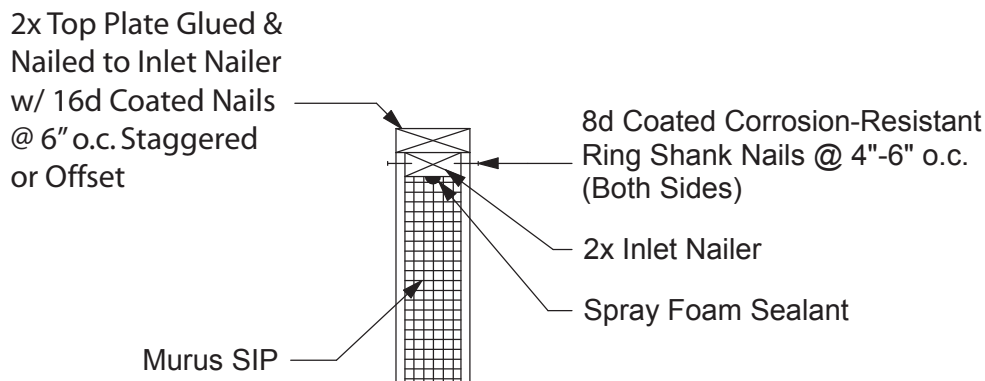

Load Bearing Top Plate Header:

A load bearing top plate header is an alternative method that is recommended when the wall panels contain a large number of window or door openings, large bearing loads, or when the wall panels are loaded by large point loads. In any case the load bearing top plate header will transfer bearing loads more evenly. Selection and sizing of the header material is determined by the span and load conditions (see Figure 7C, Page 24).

Figure 7C. Load Bearing Top Plate Header Connection Detail

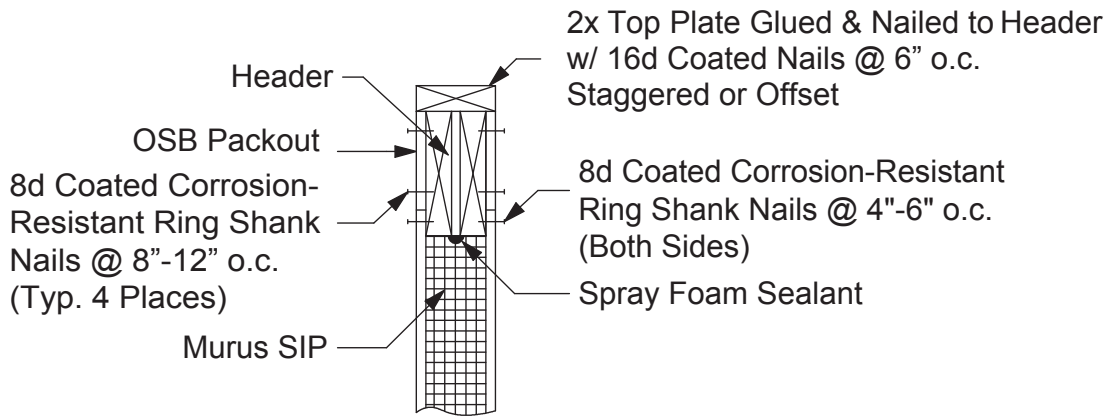

Second Floor Systems:

There are a number of ways to support the second floor system. One method is the **hung joist floor** system (also referred to as the "wrapped" system) which features a top mount joist hanger that hangs from the top plate and transfers the load from individual joists to the wall panels (see Figure 8A). The subfloor material extends out on the top plate to the exterior of the wall below, thereby further securing the connection of the floor system to the wall. This method of installing the second floor system provides the best possible continuity of insulation from the first floor to the second.

Figure 8A. Hung Joist Floor System

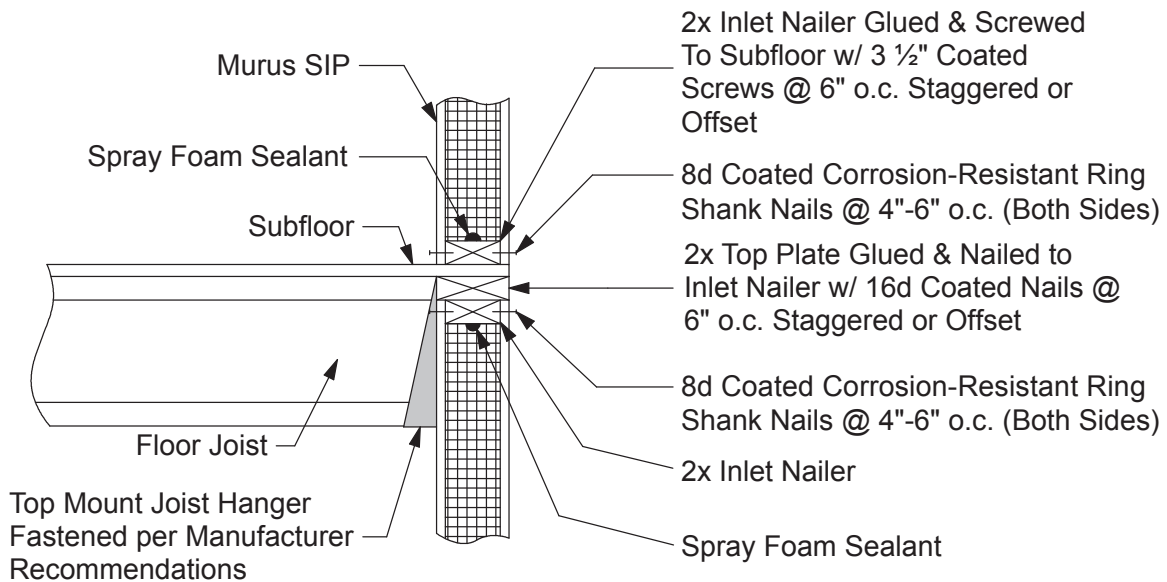

Platform Framed Second Floor:

Another way to support the second floor system is the platform framing method, wherein the second floor joists bear directly on the top plate of the first floor wall SIPs (see Figure 8B). The use of metal tie straps to connect the first floor wall panels to the second floor wall panels is recommended, and may be required, depending on local codes. With the first floor system in place, the second floor wall system can be installed. Start by gluing a 2X bottom inlet nailer to the subfloor and fastening through the subfloor and into the rim board and floor joists with 3 1/2" coated screws at 6" on center, staggered from side to side or offset.

Figure 8B. Platform Framing Joist System

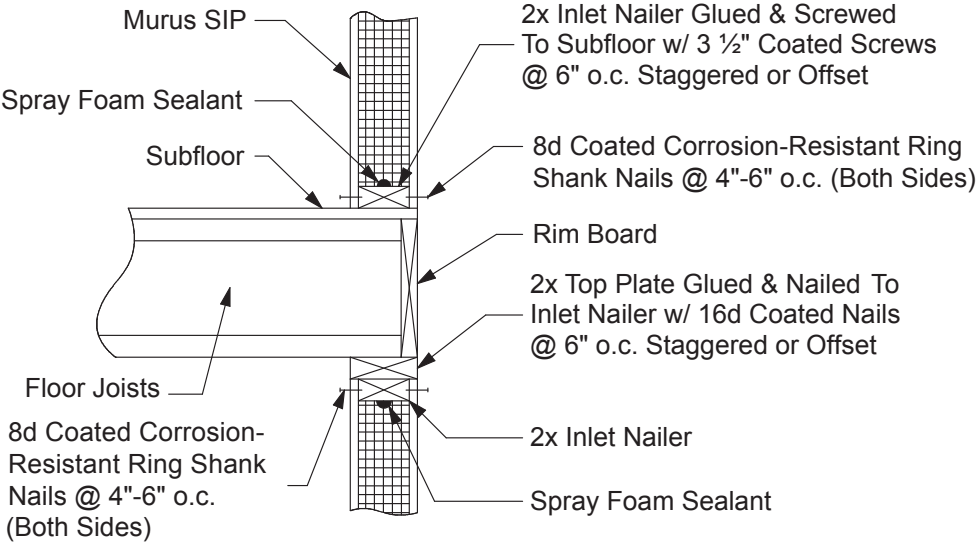

Girder/Beam Housing:

Girders or beams on the interior of the structure may be supported and housed in a girder/beam pocket in the exterior SIP wall. Depending on the loading of a beam or girder, it is housed in the panel with or without an inlet bearing post (see Figure 9).

Figure 9. Girder/Beam Housing: (with and without post)

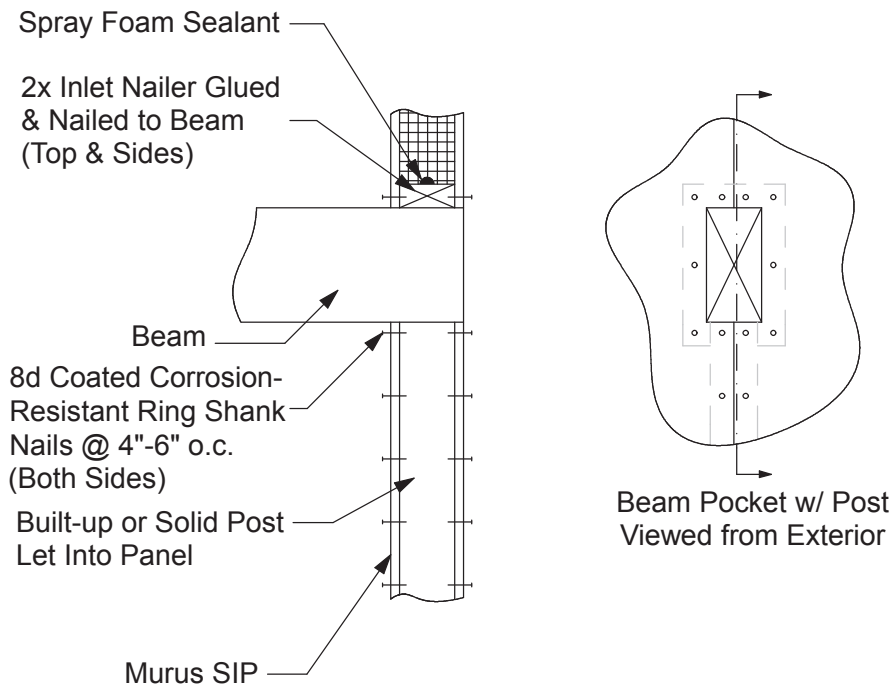
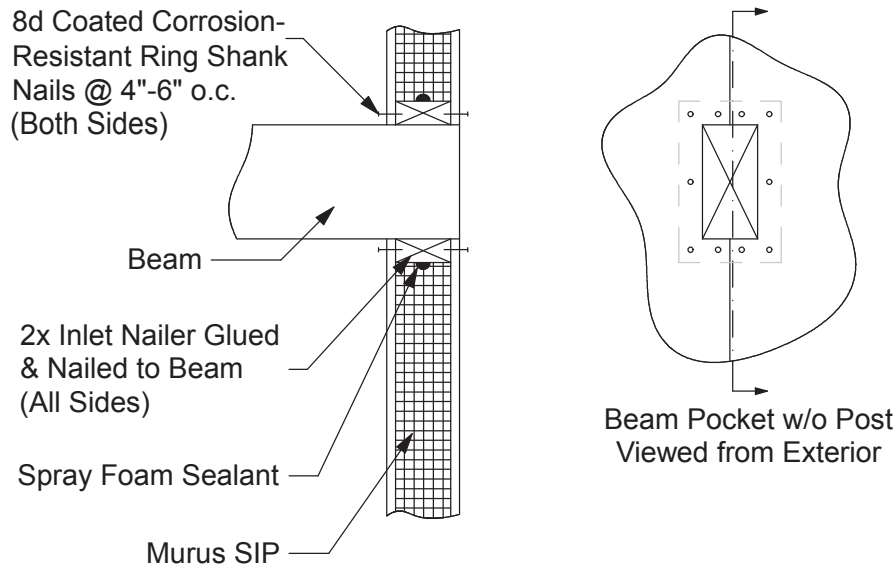

Spline Joints:

Spline joints serve many different functions in SIP construction. The following Figures 10A through 10E are examples that address these functions:

Figure 10A. Single Key-Spline Joint

Used for joining panels where cam-locks are not available in some non-bearing conditions

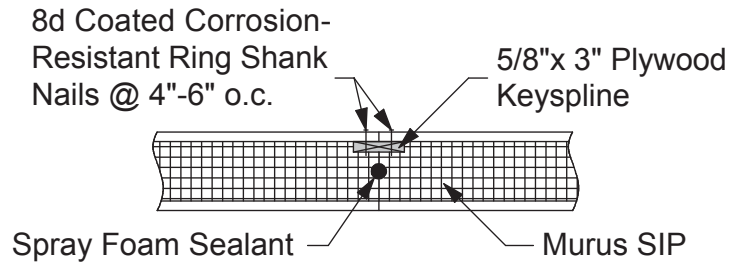

Figure 10B. Double Key-Spline Joint

Used for joining panels where cam-locks are not available in some light load bearing conditions

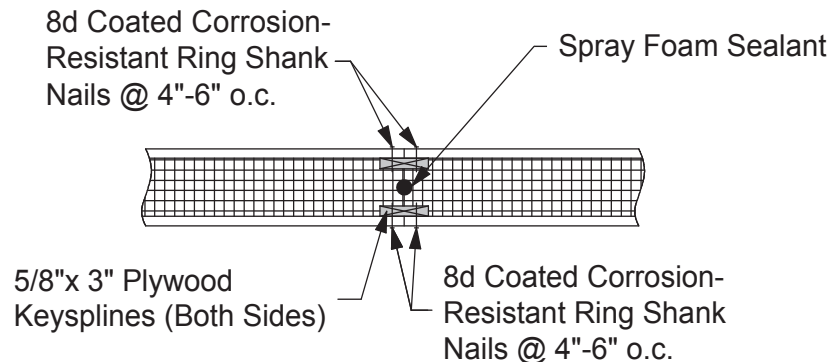

Figure 10C. Half-Housed 2X Spline

Used for joining panels in load bearing conditions

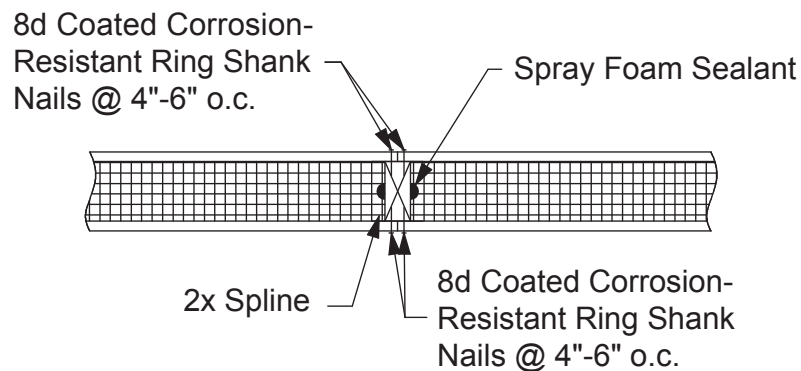

Figure 10D. Half Housed 4X (Double 2X Joint)
 Used for joining panels where extra area or heavier bearing strength is needed

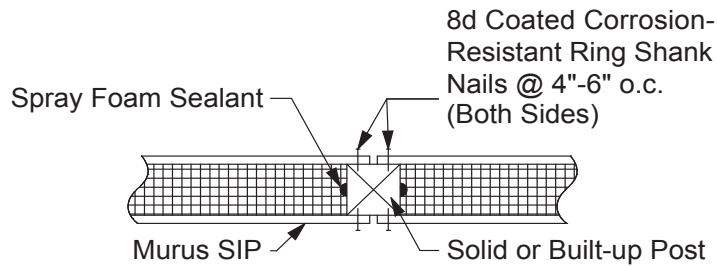
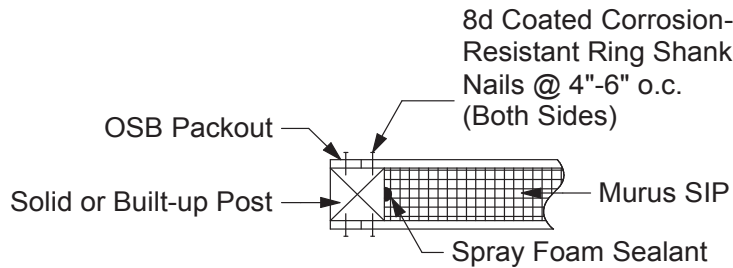

Figure 10E. Fully Housed 4X (Double 2X)
 Used for rough openings (jack posts under headers) and corners where extra nailing area or heavier bearing strength is needed



Corner Connections:

A 90 degree corner (both inside corner and outside corner) is formed by overlapping the ends of two panels or paneled walls (Figure 11A, Page 29). Both panels require 2x inlet nailers installed in the end of the panels, using liberal amounts of spray foam and 8d coated corrosion-resistant ring shank nails. Next, apply construction adhesive to the inlet which will face the OSB surface of the adjoining panel. Position the panels to form the corner, make sure both panels are plumb and the corner is square, then drive panel fasteners through the exterior panel and into the inlet nailer of the adjoining panel. Refer to Fastening Schedule on Page 12, or to the Panel Layout drawings for fastener size and spacing.

Corners which are not 90 degrees are usually formed by installing beveled blocking in between the 2x inlet nailers of the adjoining panels (Figure 11B, Page 29).

Figure 11A. Typical Corner

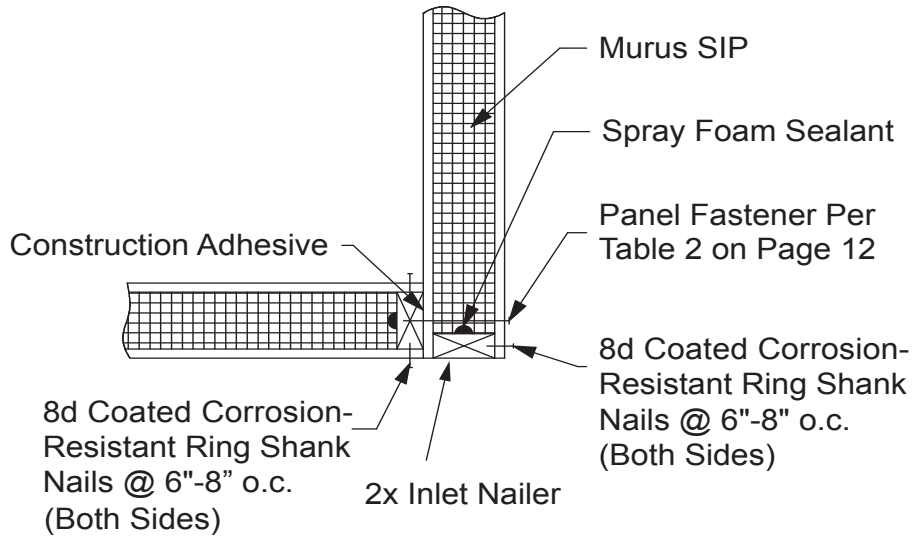
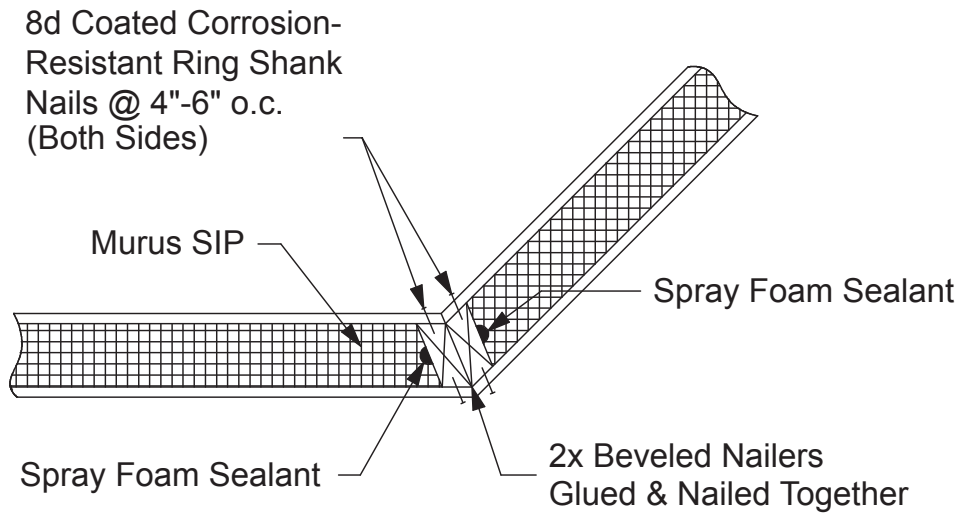

Figure 11B. Typical Corner with Miter Less Than or Greater Than 90 Degrees



Roof Framing Systems:

Manufactured trusses and rafter systems are used over SIP wall construction for many applications. Common rafter and purlin systems may be more desirable roof framing structures due to their open interior spaces and continuity of insulation. An additional advantage of the common rafter or purlin system is that the members can be spaced further apart since the structural capabilities of the roof SIPs allow them to span greater distances.

Stick Framed Roof:

Manufactured trusses or 2X rafters, typically 24" on center, generally bear fully on the top plate of the exterior wall SIP. Follow truss manufacturer's recommendations or sound framing practices for installation and ensure proper fastening to the top plate with appropriate anchors. Beneath the trusses or rafters, Murus recommends installing non-structural ceiling panels. Murus CP-2100 series ceiling panels provide continuous insulation and a complete foam core insulated building envelope. (See Figures 12A below and 12B, Page 31).

Figure 12A. Stick Framed Roof

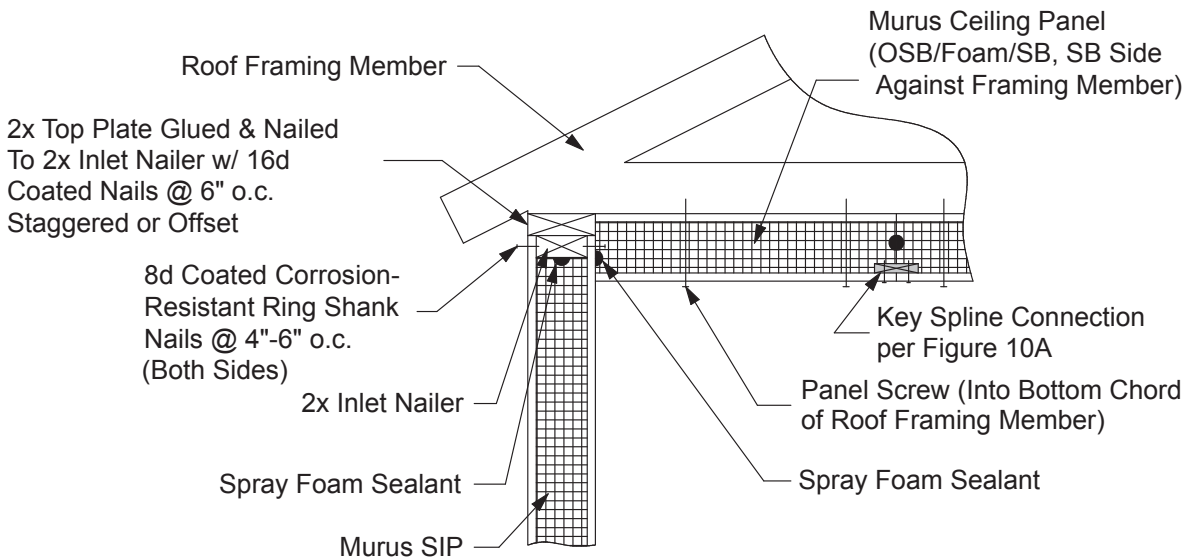
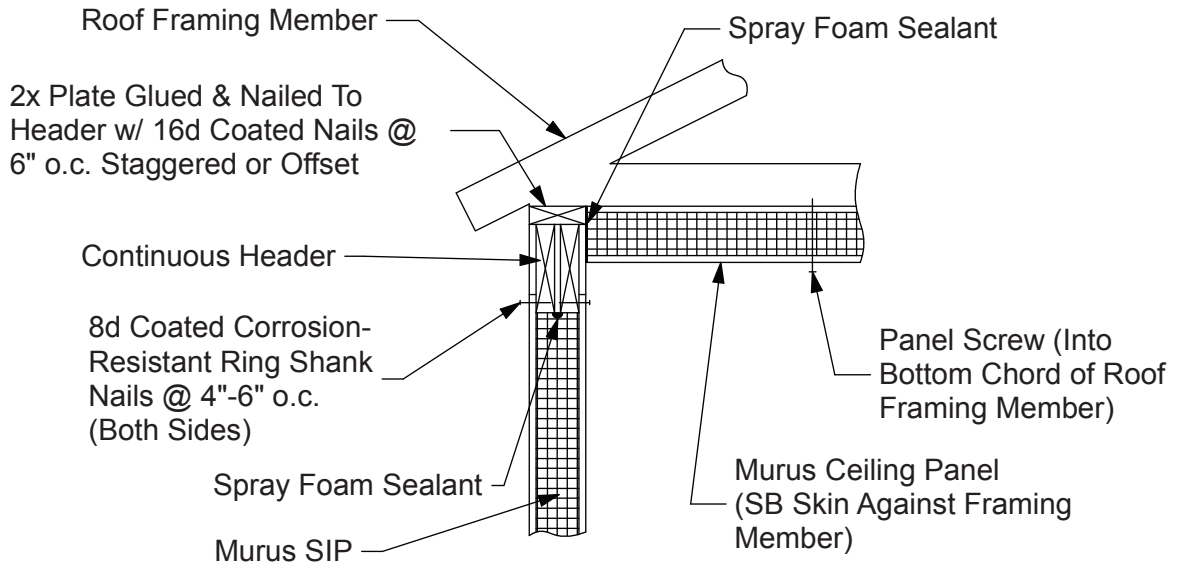

Figure 12B. Stick Framed Roof with Continuous Header Detail



Purlin Roof System:

The term 'purlin' refers to structural roof framing members, typically heavy timbers, glulam, or engineered lumber, which are installed in parallel rows up the slope of the roof. The purlins are positioned parallel to the eave of the roof, and the panels are typically applied vertically on the pitch. Each panel should span at least three purlins (simple spans are not recommended). Longer panels also help minimize the number of panel joints, and may also speed installation time. Panel spans, connections, and fastener spacing should be reviewed by a Professional Engineer and/or detailed on Murus panel drawings (see Figures 13A below, 13B and 13C, Page 32, and 13D, Page 33).

Figure 13A. Purlin Roof System

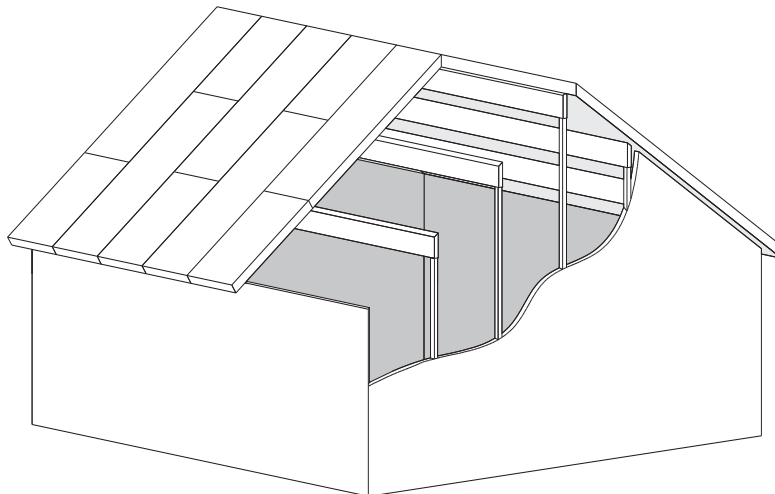

Figure 13B. Typical Detail with Purlin Roof System

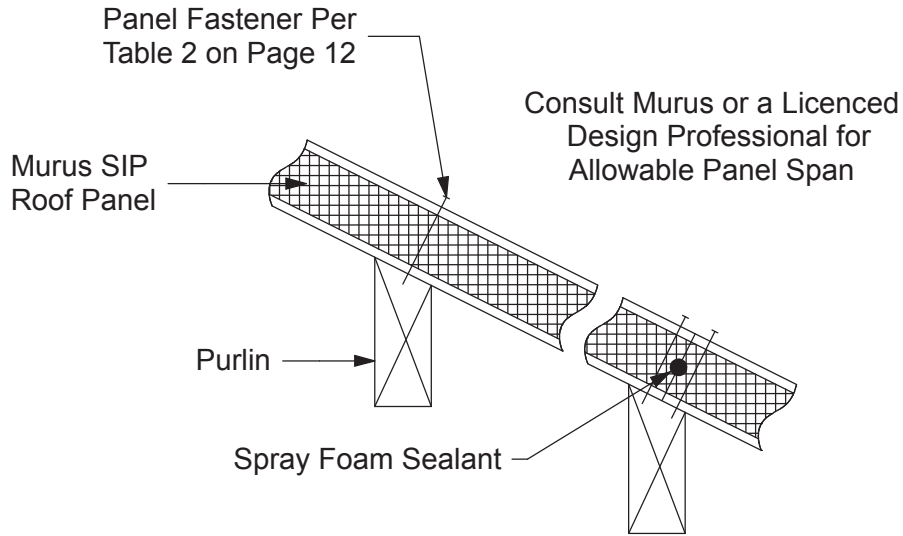

Figure 13C. Typical Eave Detail for Purlin Roof System with 2X Blocking

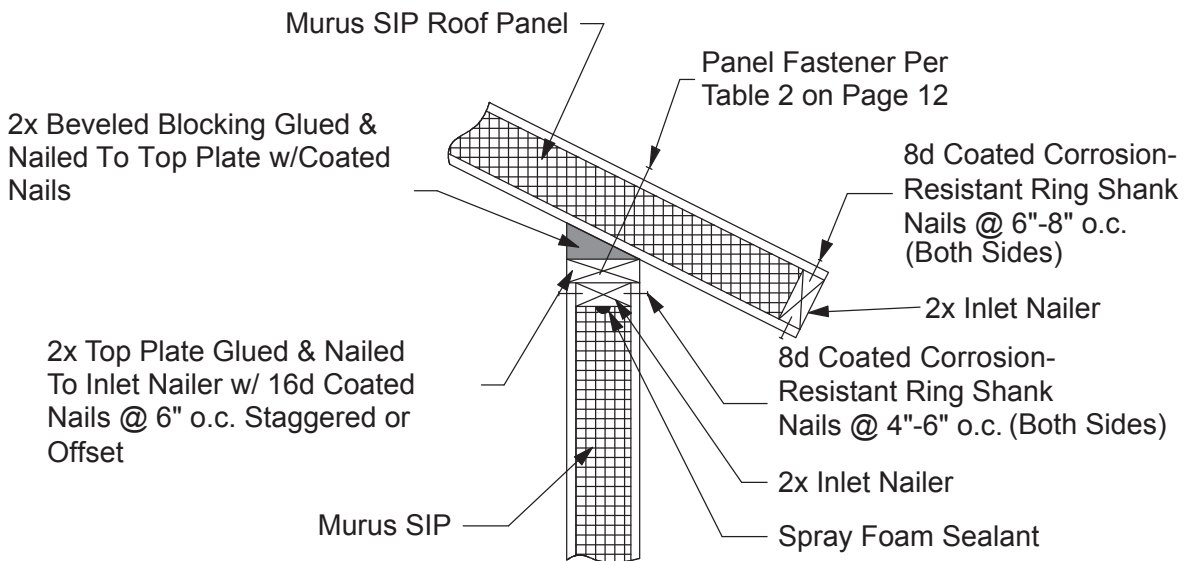
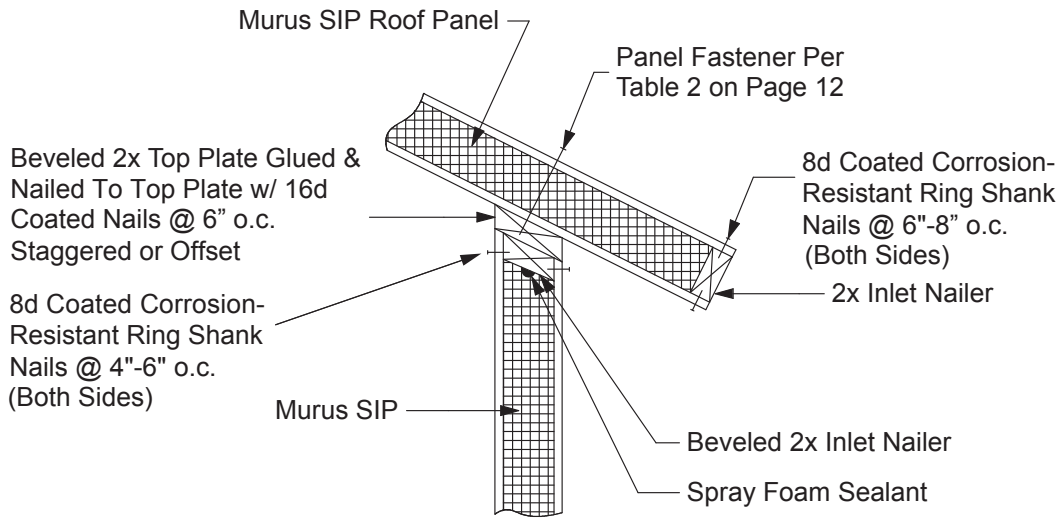

Figure 13D. Typical Eave Detail with Starter Purlin Roof System



Purlin Bearing Housing:

The purlin bearing system is identical to the girder or beam bearing system in that the same end housing details may be used. The purlins are located parallel to the eave with the top of the purlin beveled to match the pitch of the roof (see Figure 14). The loading on the member determines the size of the purlin and whether a bearing post is required, and its size. (See Rafter Bearing Housing, Page 35, for more information on installing purlins in wall panels.)

Figure 14. Purlin Bearing Housing

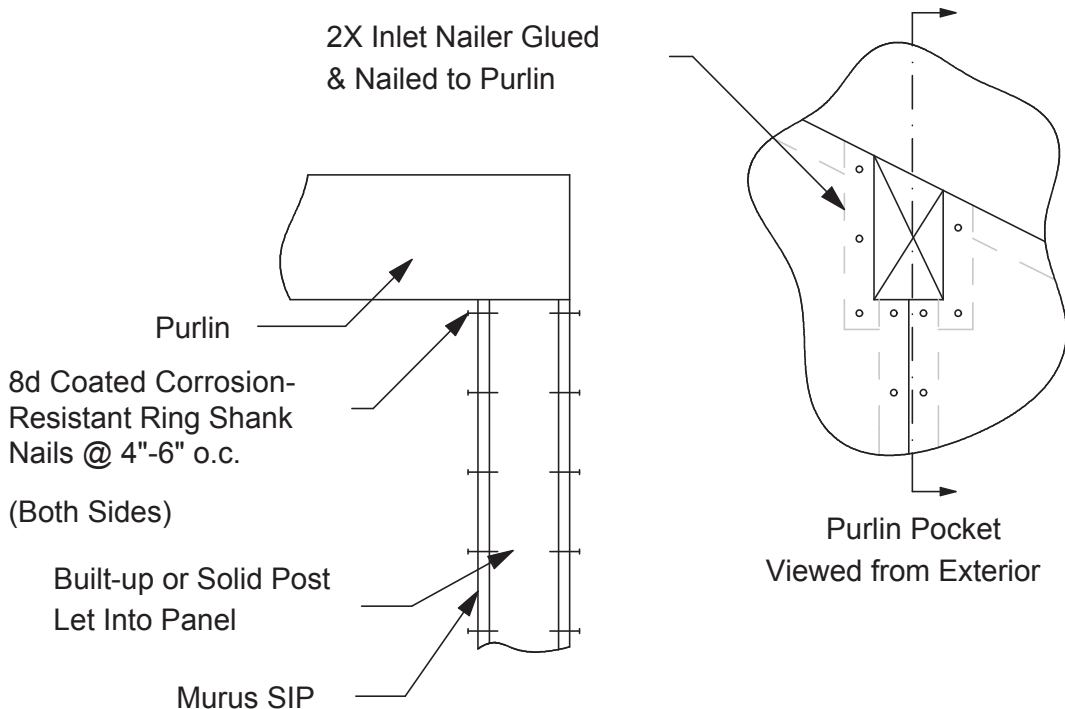

Common Rafter Roof System:

A common or main rafter system is illustrated in Figure 15. The rafters run up the slope of the roof with the panels typically installed horizontally, or perpendicular to the rafters.

Roof Panel Installation On Common Rafter System:

When installing the roof SIPs over purlins or rafters, start at the eave and work up the slope of the roof to the ridge. Pay close attention to the positioning of the first row of panels. Make sure panels are installed square to the purlins or rafters. Before fastening the panels, insure that you have the proper overhang dimensions. On succeeding rows, pay particular attention to the panel spacing. The panels have a 1/8" +/- gap between OSB skins; the 1/8" +/- gap allows the OSB skins to expand and contract with seasonal changes. It is recommended that each panel span over purlins or rafters with the 4' panel seams staggered.

As with all panel joints, liberal amounts of spray foam sealant must be applied between all mating panel edges. The foam should be applied as the panels are positioned together. Thorough foaming of all seams is required since this helps to prevent heat and moisture transmission through the roof panel joints. As with wall panels, the excess foam should be scraped off the panels when the roof finishing material is applied.

Figure 15. Typical Common or Main Rafter System Detail

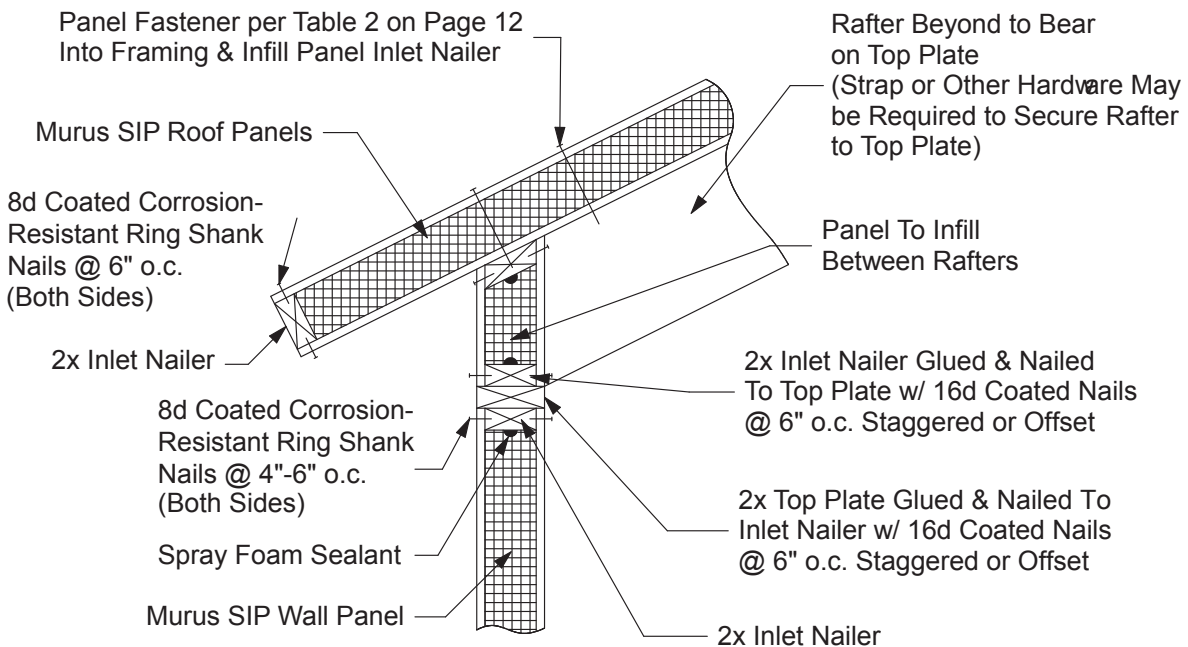

Rafter Bearing Housing:

Similar to the bearing detail for a purlin, a rafter may be housed in the panel to bear on the skins (see Figure 16A), or to bear on a post encased in the joint of the panel (Figure 16B). In either case, the end of the rafter, regardless of pitch, is collared with 2X material to form a secure connection to the panel. The 2X material is fastened to the rafter with construction adhesive and coated corrosion-resistant ring shank nails. A third instance occurs when the rafter bears on the top plate and possibly the subflooring as well. In this instance (Figures 15 and 16C), the space between rafters is filled in with SIP material, making sure to apply liberal amounts of spray foam sealant on all sides.

Figure 16A. Typical Rafter Bearing on Murus SIP Detail

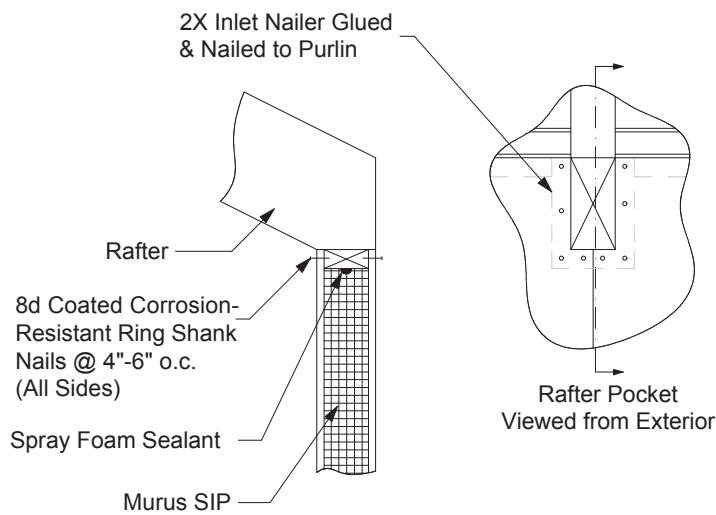

Figure 16B. Typical Rafter Bearing on Post Detail

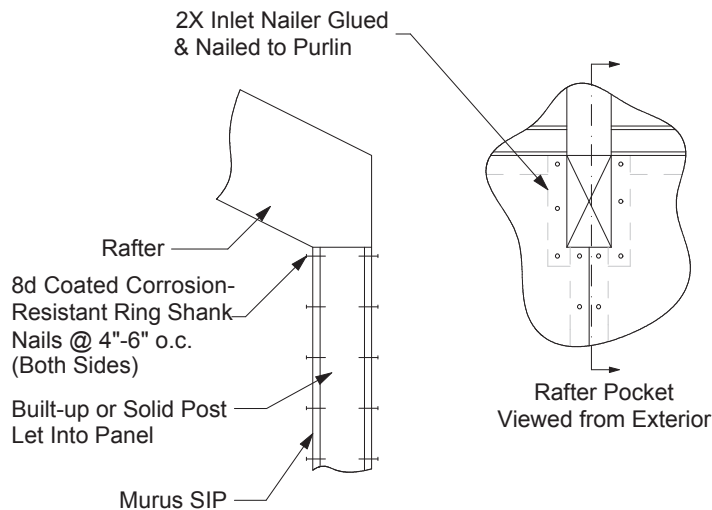
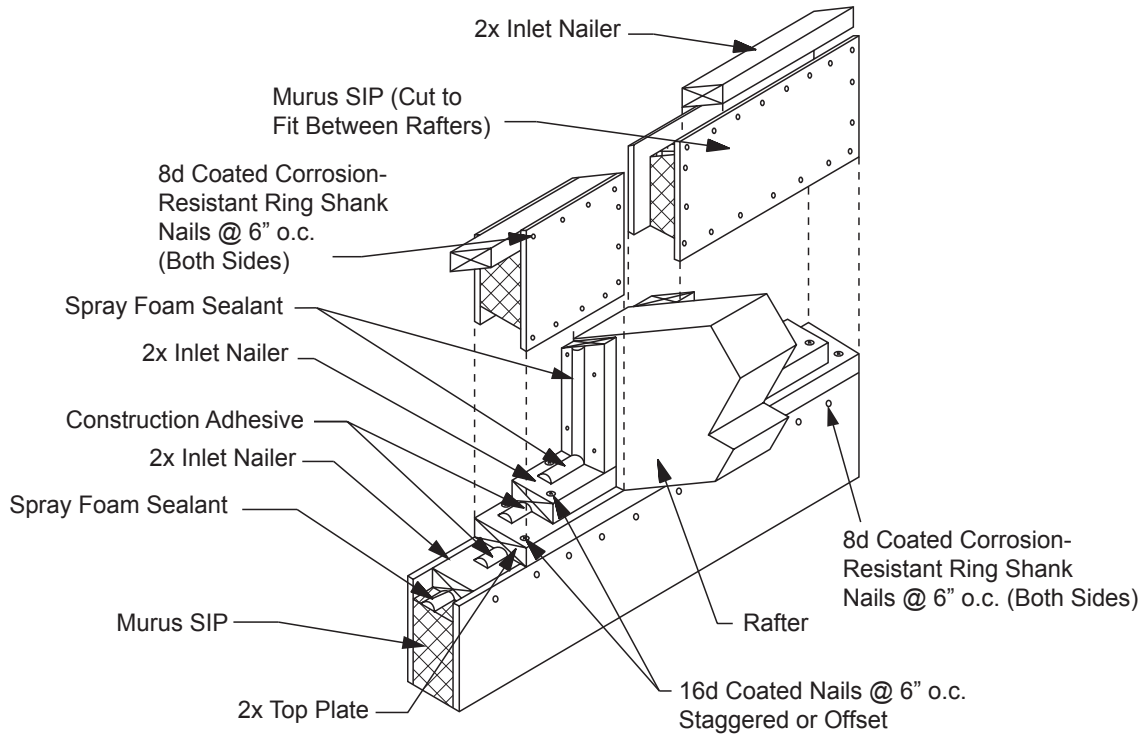

Figure 16C. Typical Rafter Bearing on Top Plate Detail



Cantilevering Roof SIPs:

To create both eave and rake fascia and soffit, the roof panel may be cantilevered beyond the exterior of the wall. Consult with Murus or a Professional Engineer for installation and connection details

Eave Details:

Figure 17A shows the typical squared eave construction detail where an inlet nailer is fully housed in the end of the panel, and nailed with 8d coated corrosion resistant ring shank nails at 6" - 8" on center from the top and bottom sides.

Figure 17A. Eave Detail

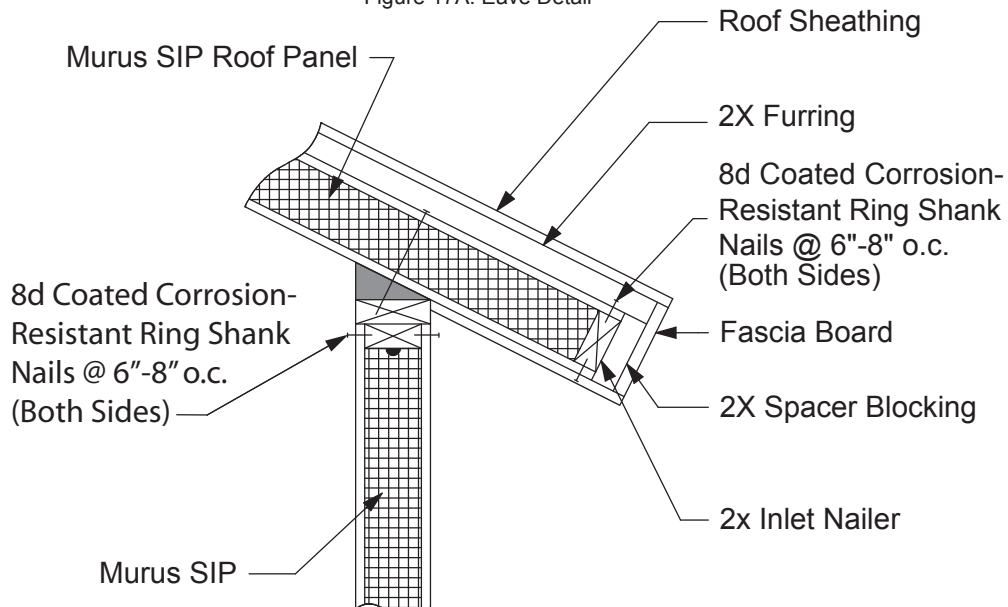

Figures 17B and 17C show “plumb” eave/fascia details with different soffit applications. A plumb fascia detail can be created by plumb-cutting the edge of the panel and installing a custom-cut nailer, but Murus recommends attaching beveled blocking on the end of a square-cut roof panel. In addition, Figures 17A, 17B, and 17C show a vented roof, which is explained further on page 55.

Figure 17B. Soffit and Fascia Options

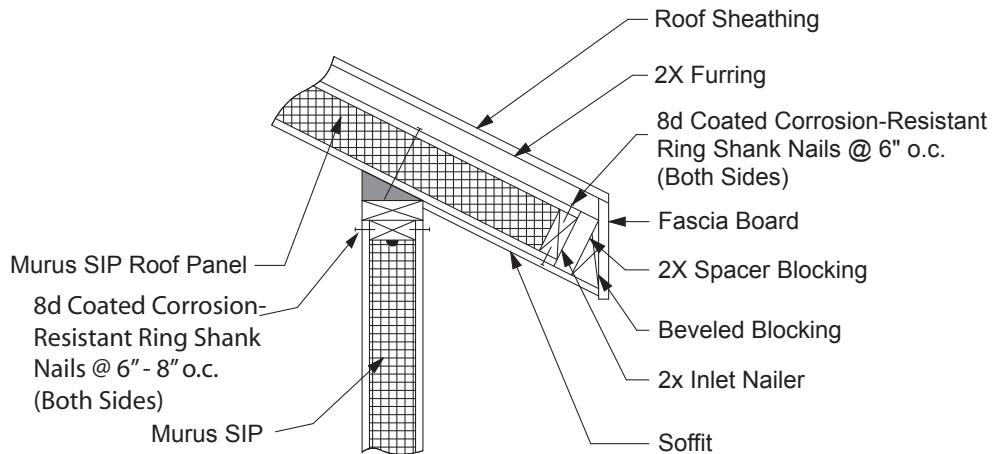
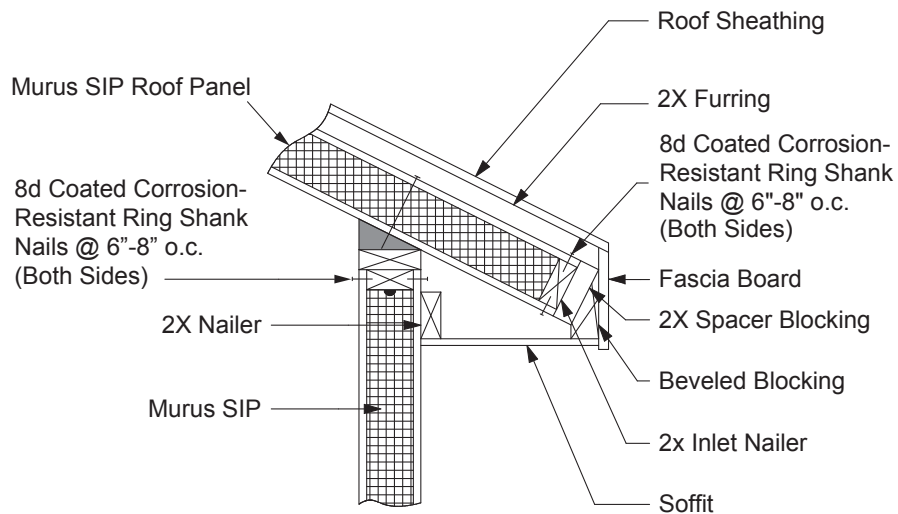
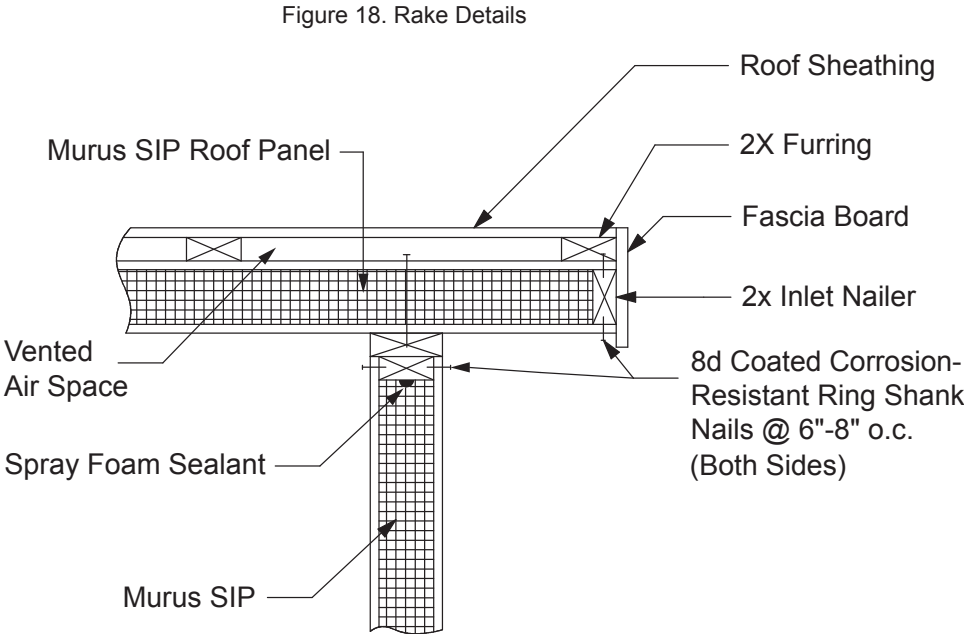

Figure 17C. Soffit and Fascia Options



Rake Details:

Figure 18 shows a typical rake construction detail with an inlet nailer fully housed in the end of the roof panel and fastened with 8d coated corrosion-resistant ring shank nails at 6" - 8" centers through both top and bottom skins. As with the inlet nailers in wall panels, the butt ends of roof panel inlet nailers must be offset from panel-to-panel joints.



Roof Peak or Ridge Details:

Two typical ridge details are shown in Figure 19A and 19B. Figure 19A is most common when utilizing a ridge beam. Here the joining roof panels are simply mitered and sealed with liberal amounts of spray foam sealant as they are fastened to the ridge beam, with appropriately sized panel nails or screws (per Fastening Schedule, Page 12). Figure 19B illustrates an optional detail for use with a 12:12 pitch only.

Figure 19A. Typical Roof Peak or Ridge Detail

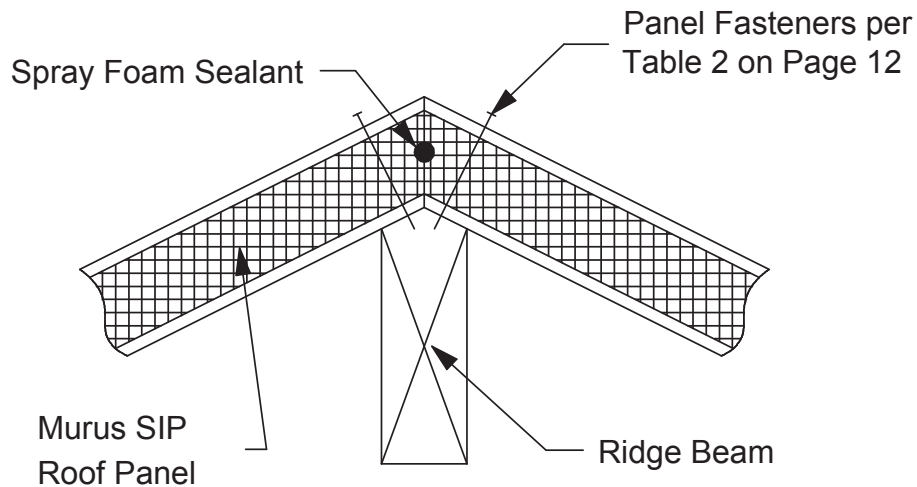

Figure 19B. Optional Roof Peak or Ridge Detail for 12:12 Pitch

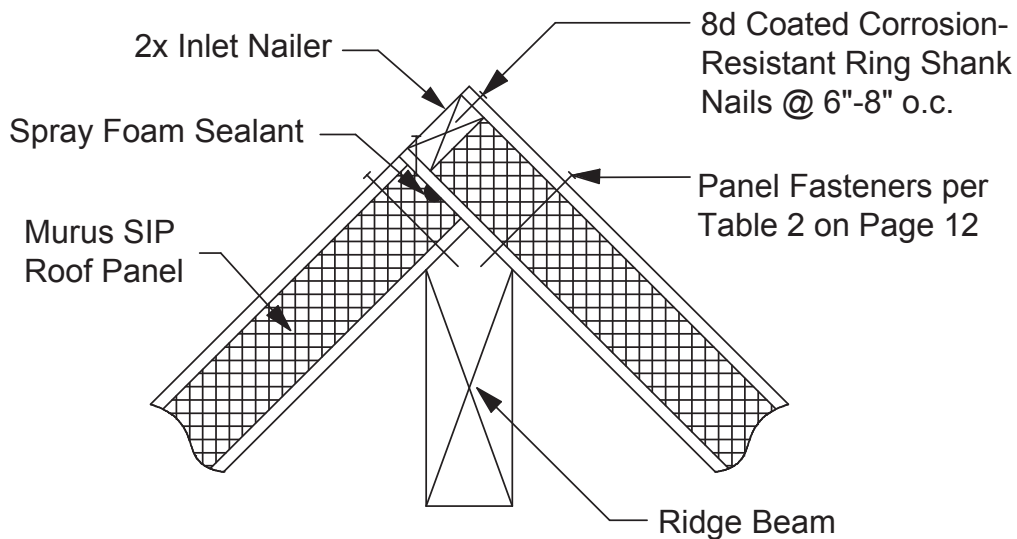
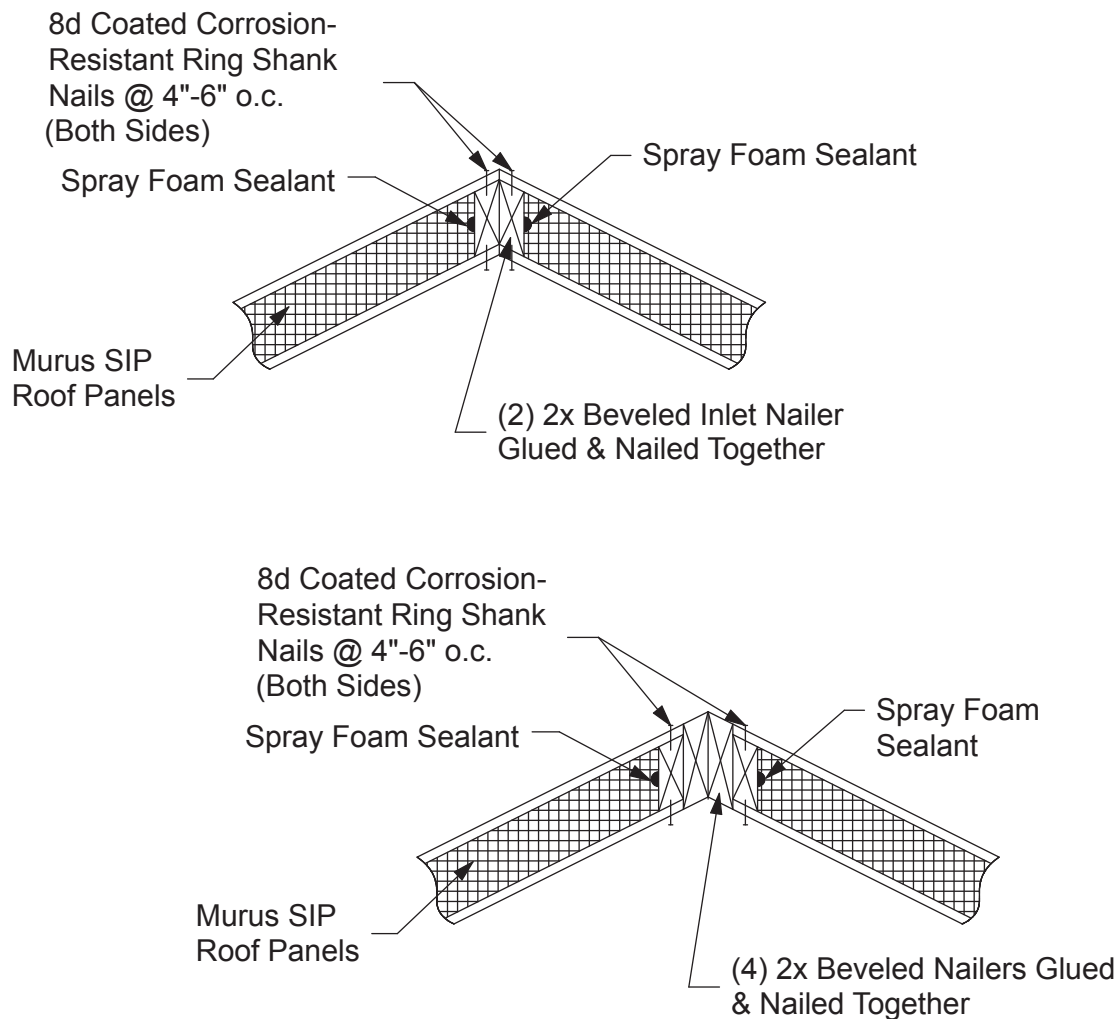

Figure 19C illustrates two structural ridge details. These details are used in the absence of a ridge beam or in conjunction with a ridge beam under certain spans and/or loading conditions.

The panels are mitered to the correct angle and routed to accept an inlet 2x nailer which is beveled to match the roof pitch. The nailers are fastened together, using coated corrosion-resistant ring shank nails and construction adhesive to form a continuous member for the length of the ridge. This member creates the ridge and provides the panel connection. Spray foam sealant is applied between the nailer and the foam core of the panel as the panels are installed. The panels are then fastened to the 2x nailers with 8d coated ring shank nails at 4" - 6" on center from both sides.

Figure 19C. Structural Ridge Details



Installing Nailers in Rough Openings:

Rough opening details are similar for doors, windows, and skylights. The measurements for the position of the rough opening are taken from the panel drawings or the architectural drawings. After cutting and routing the openings and installing the panels, the openings are foamed with liberal amounts of spray foam sealant, and nailers installed as shown in Figure 20A.

The bottom (sill) and top (header) nailers (1) should be installed first. They should be cut 3" longer than the opening dimension so they will run 1½" past each side of the opening and allow the side (jack) nailers (2) to bear. Spray foam sealant should be applied between the nailers and the foam core. Once the nailers are fully set into the openings, the nailers are fastened with 8d coated ring shank nails at 6" - 8" on center from both sides.

Figure 20A. Rough Opening Details

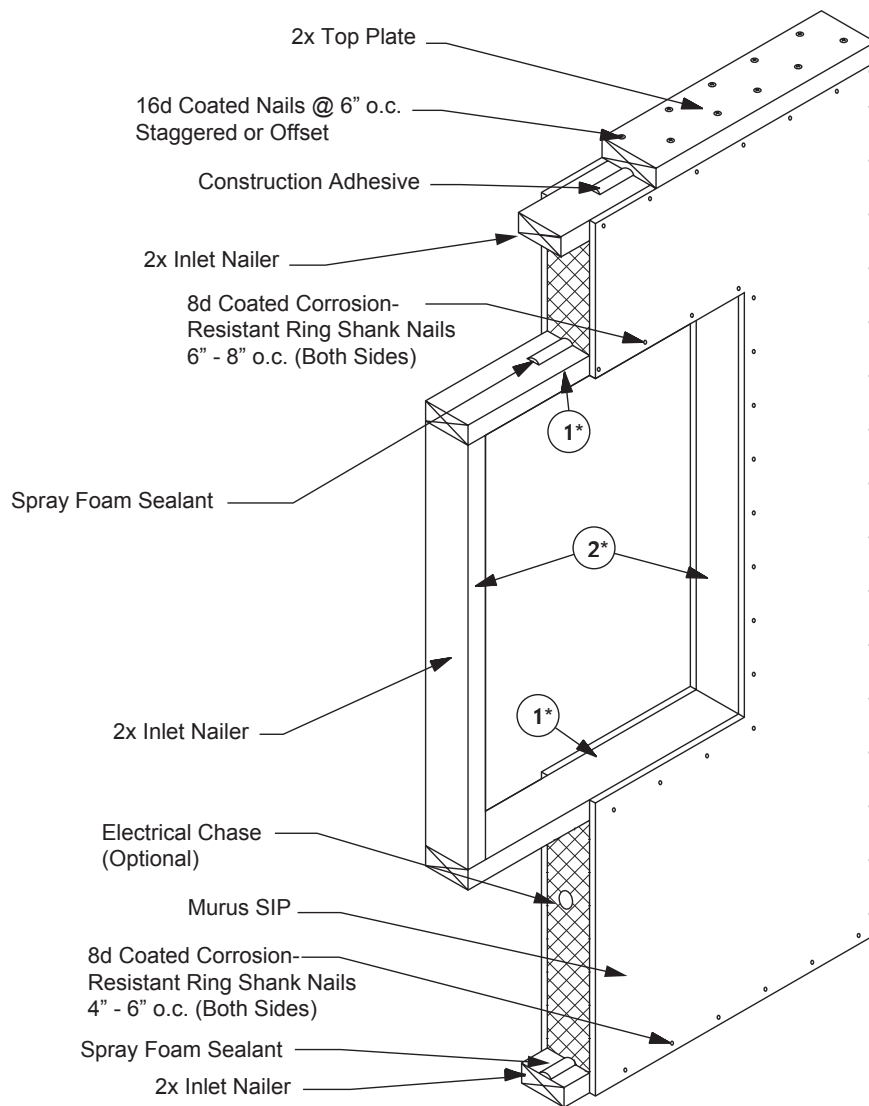

*1 = Install First; *2 = Install after all #1's have been installed

Installing Headers In Rough Openings:

Headers may be required to support and transfer loads over openings in SIP walls. Unlike most conventional framing, most panel headers are positioned at the top of the wall and sit fully on at least two studs (posts or jack studs) on each end of the header. While each installation may require some variation on an installation procedure, Murus recommends cutting the 2x inlet posts to the correct length and connecting them together with construction adhesive and nails or screws. Once the wall panel next to the 'headered' opening is installed and braced, the 2x inlet post can be installed in the panel with liberal amounts of spray foam and 8d ring shank nails. At this point, if there is a piece of wall panel below the opening, it can be installed or at least set into position. If there is a piece of wall panel above the opening, it should also be set into the opening, but left loose; it will be slid up into its position once the header is installed. Next, position the wall panel and posts on the opposite side of the opening. Once braced, the header can be installed so it sits on the bearing surfaces of the posts. If there are pieces of wall panels above and/or below the opening, these can be attached to the posts and the header at this time and the header and sill inlet nailers can be installed. If there is a top plate on the wall assembly, it should run continuous over the header and onto the panels on either side. Once the top plate is installed, 7/16" OSB can be attached to the header to match the surface planes of the SIP walls.

Figure 20B. Rough Opening Detail With Support Header

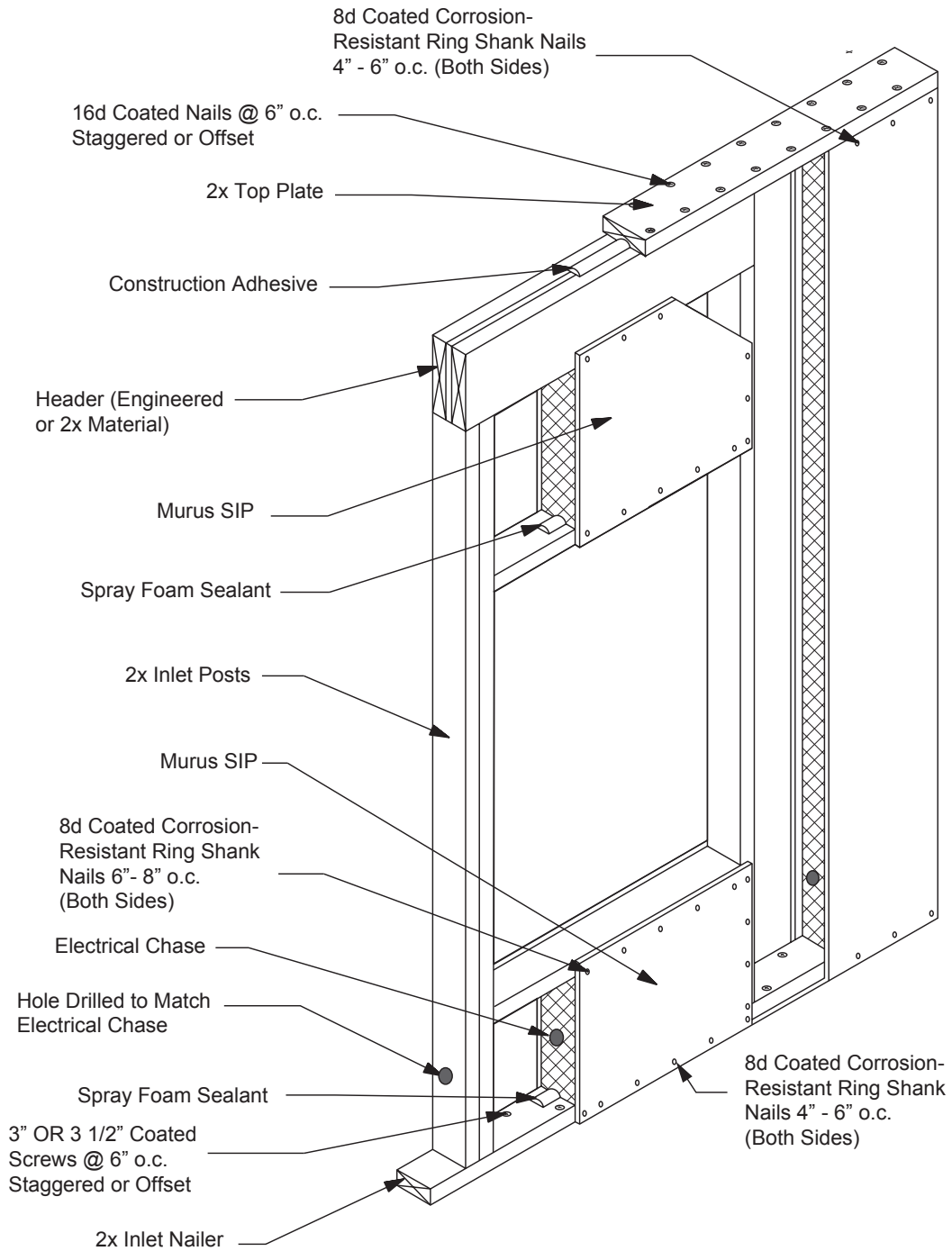

Installing Doors, Windows, and Skylights:

Always install door, window, and skylight units plumb, square, and according to the manufacturer's recommendations. When installing flange mounted units, pay close attention to the nailing flanges. Flanges that are bent or warped or are not straight and perpendicular to the unit may cause many problems later with trim and finishing details.

Before you shim and nail the unit to the 2x nailer in the rough opening, you should first check to ensure that the unit's jambs are flush or at an equal distance to the interior side of the wall. If inconsistencies are found, it is recommended to adjust the unit to remove the inconsistencies. This can be accomplished by first securing the top, bottom, side, or corner of the unit that is correct, then adjust the area(s) in or out as required, then shim the unit and secure in place. Check to ensure there is a gap between the window and the rough opening to allow for proper sealing of the unit.

NOTE: Once the unit is secured and before setting the nails, check the operation of the unit for smooth and free movement.

After installation of the unit and before applying the interior trim, the gaps around the rough opening are to be sealed with **minimally expanding** spray foam sealant. The spray foam sealant should be applied in multiple small applications until the cavity is filled.

IMPORTANT: Allow each application to cure (12 - 24 hours) before applying the next layer.

Correct spray foaming procedures will help prevent the possibility of pinching and/or bowing of the jambs caused by excessive pressure that may be created by the expansion of the foam during the curing process. Overfilling may cause the unit to bind or stick during operation. If this occurs, simply relieve the pressure by cutting away the foam and re-applying correctly. The unit is now ready for trim and finishing. For more information, see **Sealing with Spray Foam Sealant** on Page 21.

WIRING

Murus recommends that all wiring conform to applicable local, state, and national codes.

With Murus SIPs, electrical circuits can easily be run through the exterior walls during or after panel installation. While wiring the interior stud walls is the same as in conventional construction, the standard electrical chase embedded in the foam core of the Murus panel makes wiring the exterior panel wall fairly simple.

A little forethought toward the design of the electrical system can save a lot of time and aggravation. Generally all, or most all, wiring can be accomplished after panel installation, provided that access to the electrical chase is established during installation. It is recommended that an electrician be on site during the panel installation to insure that there is adequate access for the required wiring.

The 1" diameter electrical chase runs horizontally at a predetermined height in the wall panels. Access to the electrical chase can be accomplished through exterior corners, exterior door openings, or anywhere the foam core is exposed. Instead of covering the chase in the corner panel with the 2X inlet nailer, the 2X nailer can be cut short or be left out until after the wiring is complete. This allows easy access to the chase(s) for pulling or pushing electrical wiring.

IMPORTANT: In either case the nailer must be replaced as soon as the wiring is complete.

Where an interior partition wall meets an exterior panel wall is also a good location to gain access to the electrical chase. Where posts or bearing members are let into the panel, a 1¹/₄" hole must be drilled in the wood member in line with the chase to ensure continuous access through the electrical chase.

Generally, electrical circuits run from the receptacle boxes through the chase and lead back to the electrical panel through the floor framing and/or interior partition walls. Wires can be led through the horizontal panel chases, vertical panel seams, behind inlet nailers, interior partition walls, floor framing, exposed/unframed corner connections, and door rough openings. For slab construction, access is made through a conduit run to the exterior sill or interior partition walls.

Accessing Electrical Receptacles:

The electrical chase in the panels can be used to run wires to both interior and exterior receptacles. The chase will be at a constant predetermined height along each wall (refer to panel drawings or Murus Sales Order). Determine the location of and cut all receptacle boxes before running wires (this will help eliminate the possibility of cutting the wire).

Locate the top or bottom of the receptacle box at the chase height. Using a keyhole saw, router, jigsaw, or spiral saw, cleanly cut through OSB to the chase depth (see Figure 21). Remove the OSB cutout and then remove foam to the required depth for the box. Run the wires from box cut-out to box cut-out, pull wires through the box and secure the box to the OSB. When running wires it is recommended to run from box to box as opposed to pulling loops. At interior wall locations, be sure to leave enough wire coiled to reach the next in-line receptacle (see Figure 22 on Page 47). When using interior walls it is recommended to break rooms up into circuits (see Figure 23 on Page 47).

NOTE: Be sure to seal around all receptacle boxes with spray foam sealant **after** electrical wiring has been completed.

Figure 21. Typical Receptacle Box Installation

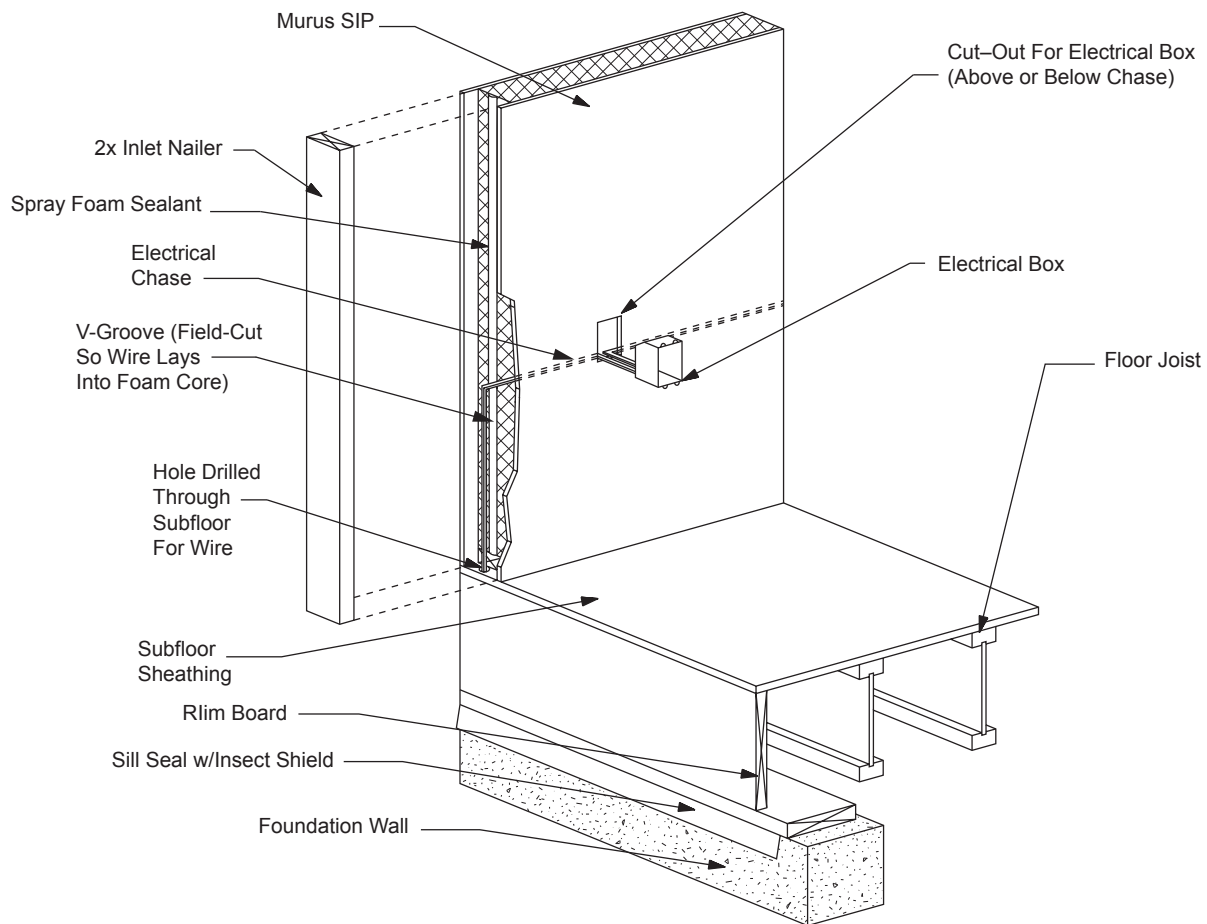

Figure 22. Typical Interior Wall Receptacle Box Wiring

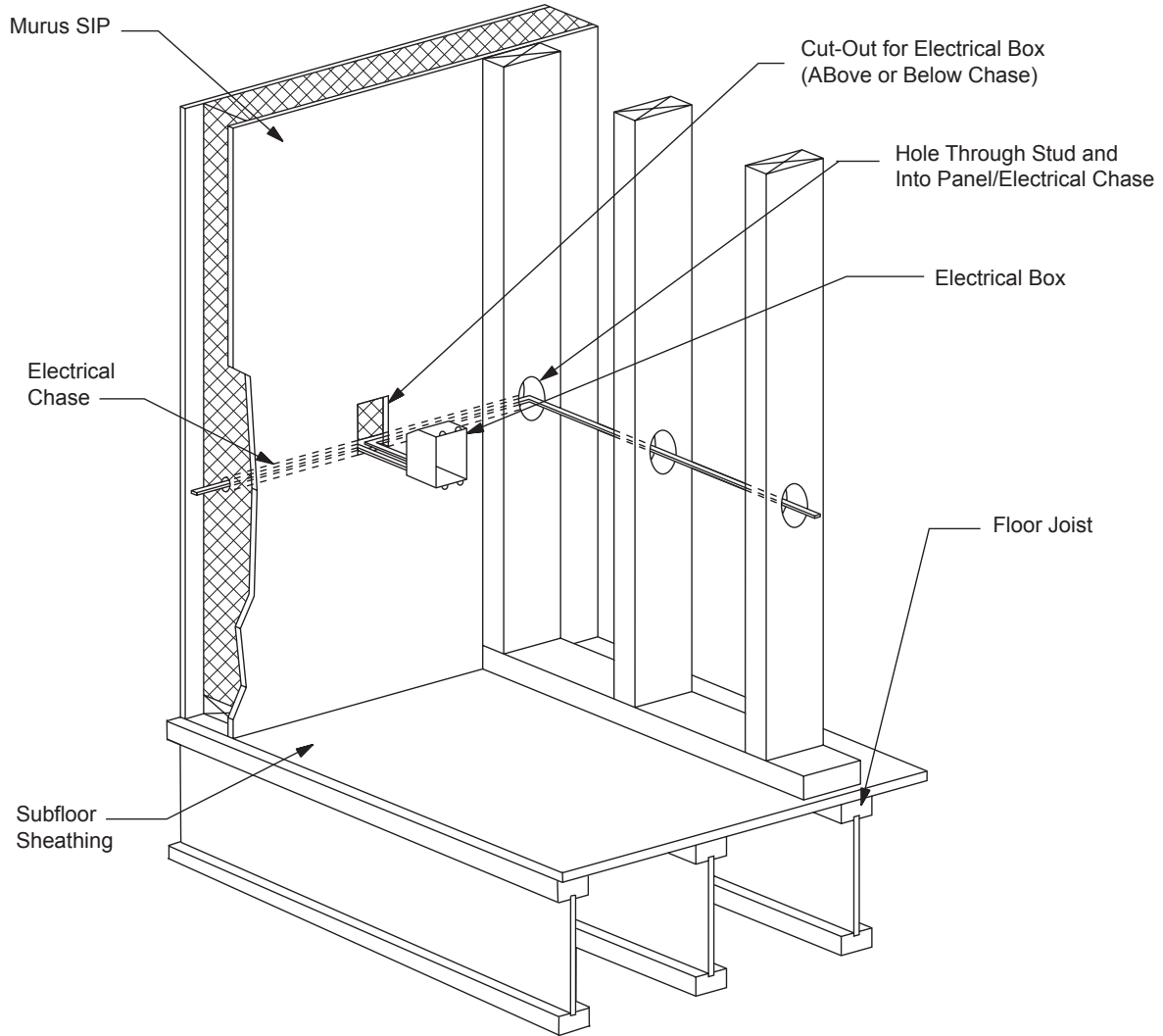

Figure 23. Typical Electrical Circuit Layout

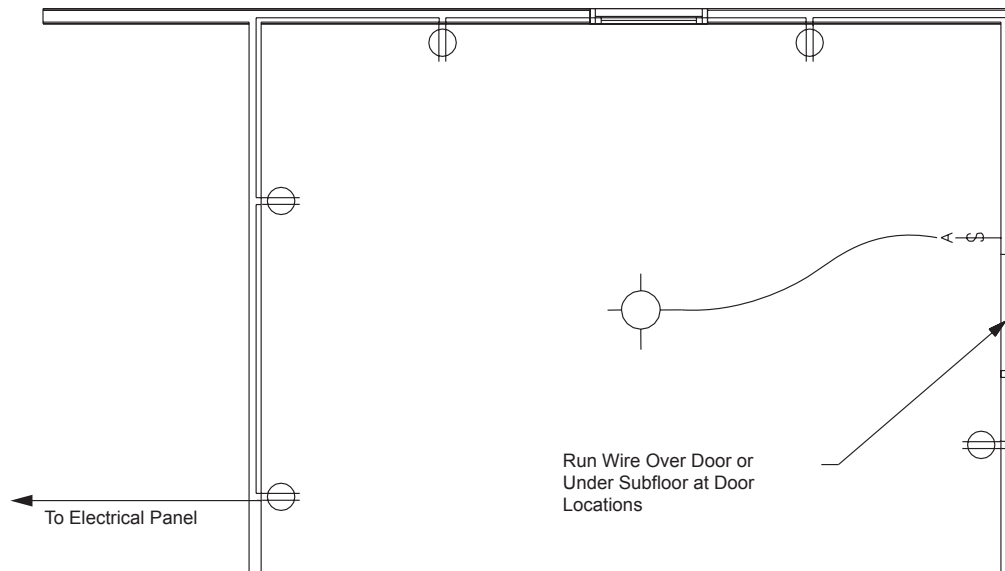
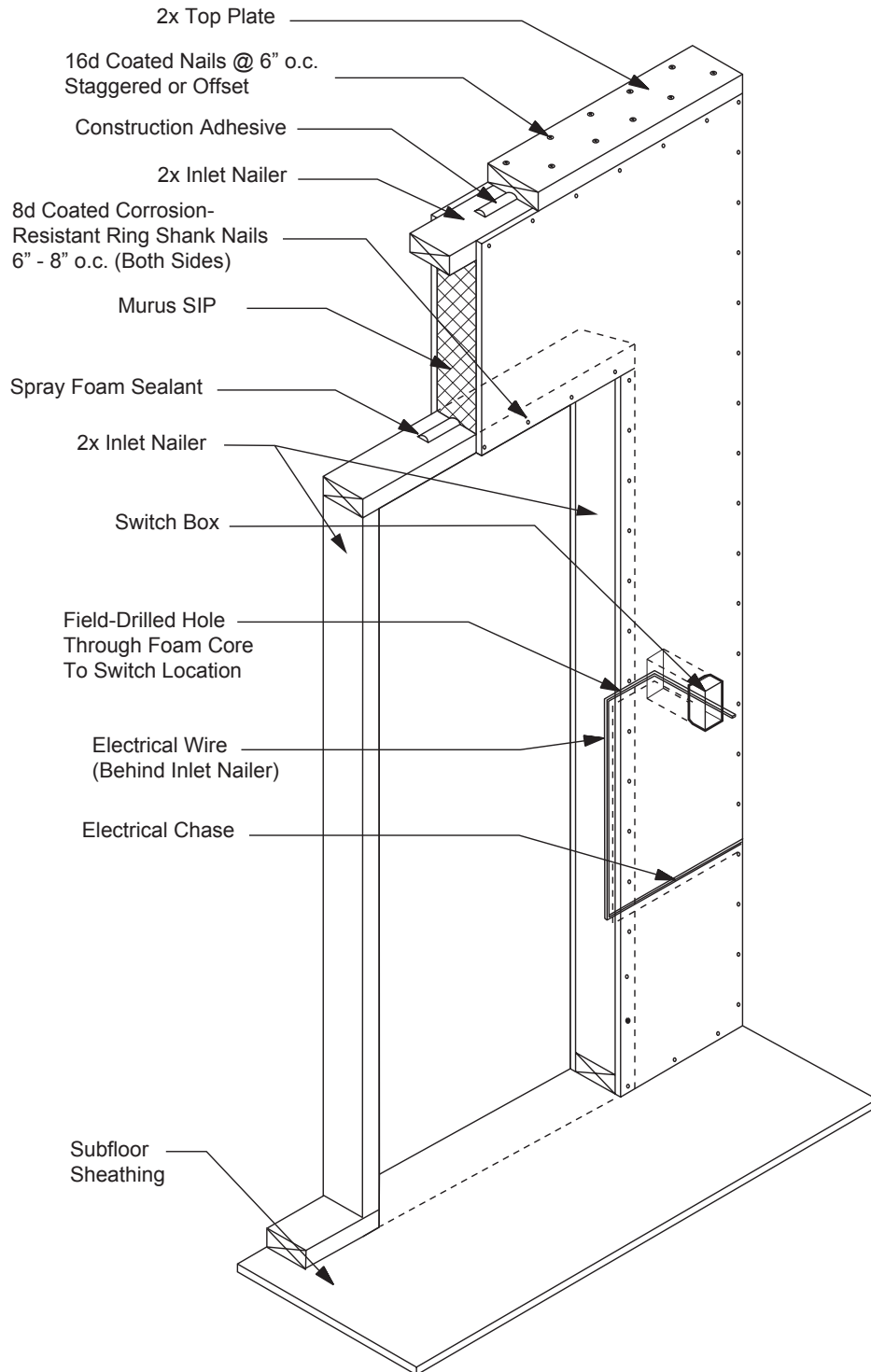

Figure 24. Typical Electric Switch Box Installation



Accessing Light Switches:

For exterior wall switch box locations, it is common practice to locate the boxes next to a door opening (see Figure 24 Page 48). Access to boxes is accomplished through the door rough opening. After the foam is routed out and before the inlet nailer is installed, locate and cut the hole for the box (as explained in the previous paragraph). From the rough opening of the door, drill a hole large enough to fit the electrical wires to the switch, horizontally to the hole cut for the electrical box. Using a utility knife or other tool, create a groove in the foam core where the inlet will be installed, making the groove large enough to accept the wires. This will ensure the 2X inlet will sit flush with the OSB skins when installed. Run the wires from the electrical chase up the groove in the foam and through the horizontal hole to the box location before installing the 2X inlet.

Establishing Wiring Access to the Second and Third Floor:

To run wiring vertically up to the second floor areas, outdoor lighting, etc., the best method is to use the conventional framing of interior partition walls which intersect the exterior SIP walls.

Wiring in Roof Panels:

Roof panels typically do not include a horizontal electrical chase. Instead of using a chase on roof panels, wiring is run between the seams of the panels during installation to bring power to overhead ceiling lights or fans (see Figure 25 on Page 50).

Figure 25. Typical Wire Detail At Roof Panels

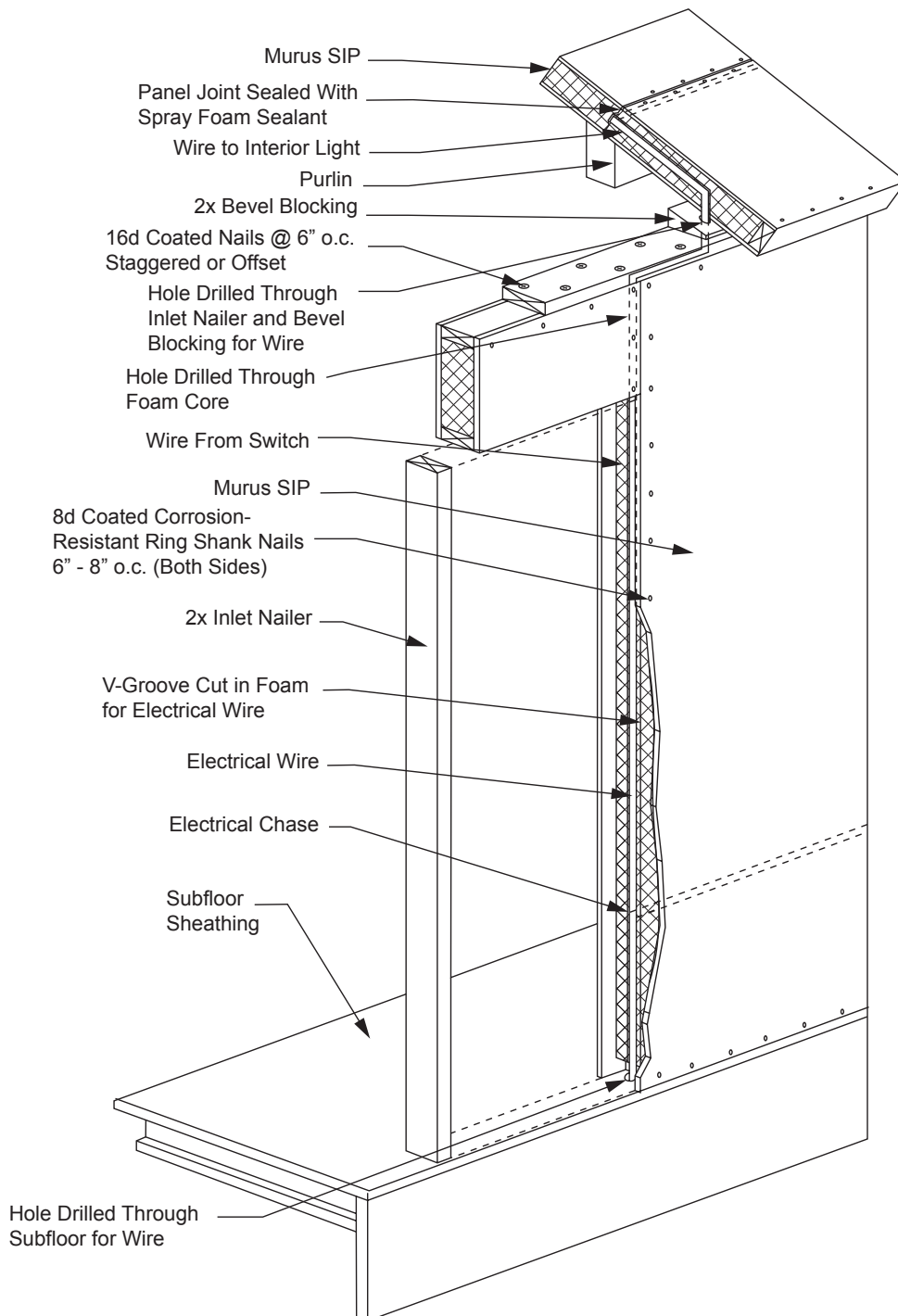

Wiring Around Doors and Windows:

Refer to Figure 26 below and Figure 27, Page 52, for details.

Figure 26. Typical Wiring Around Doors

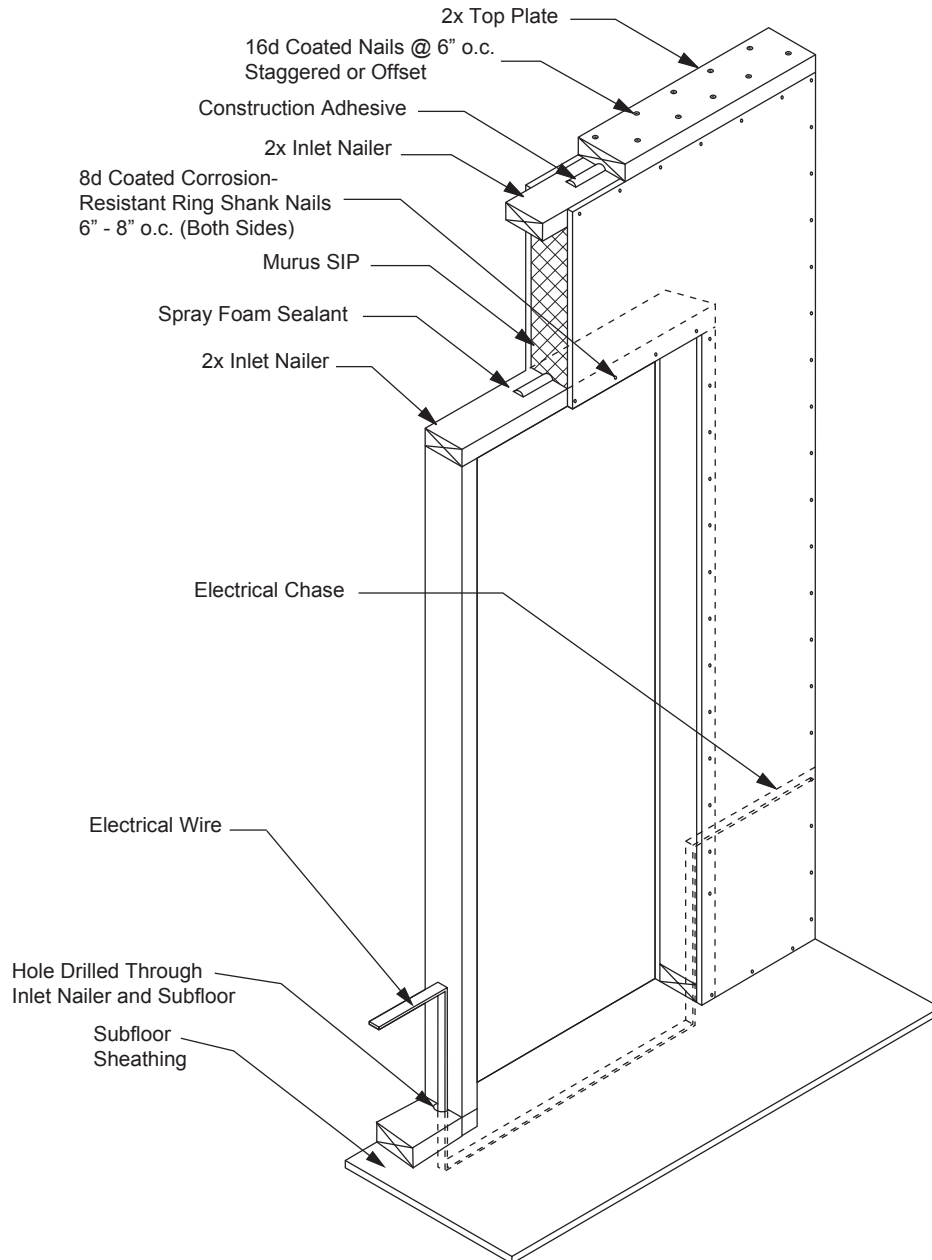
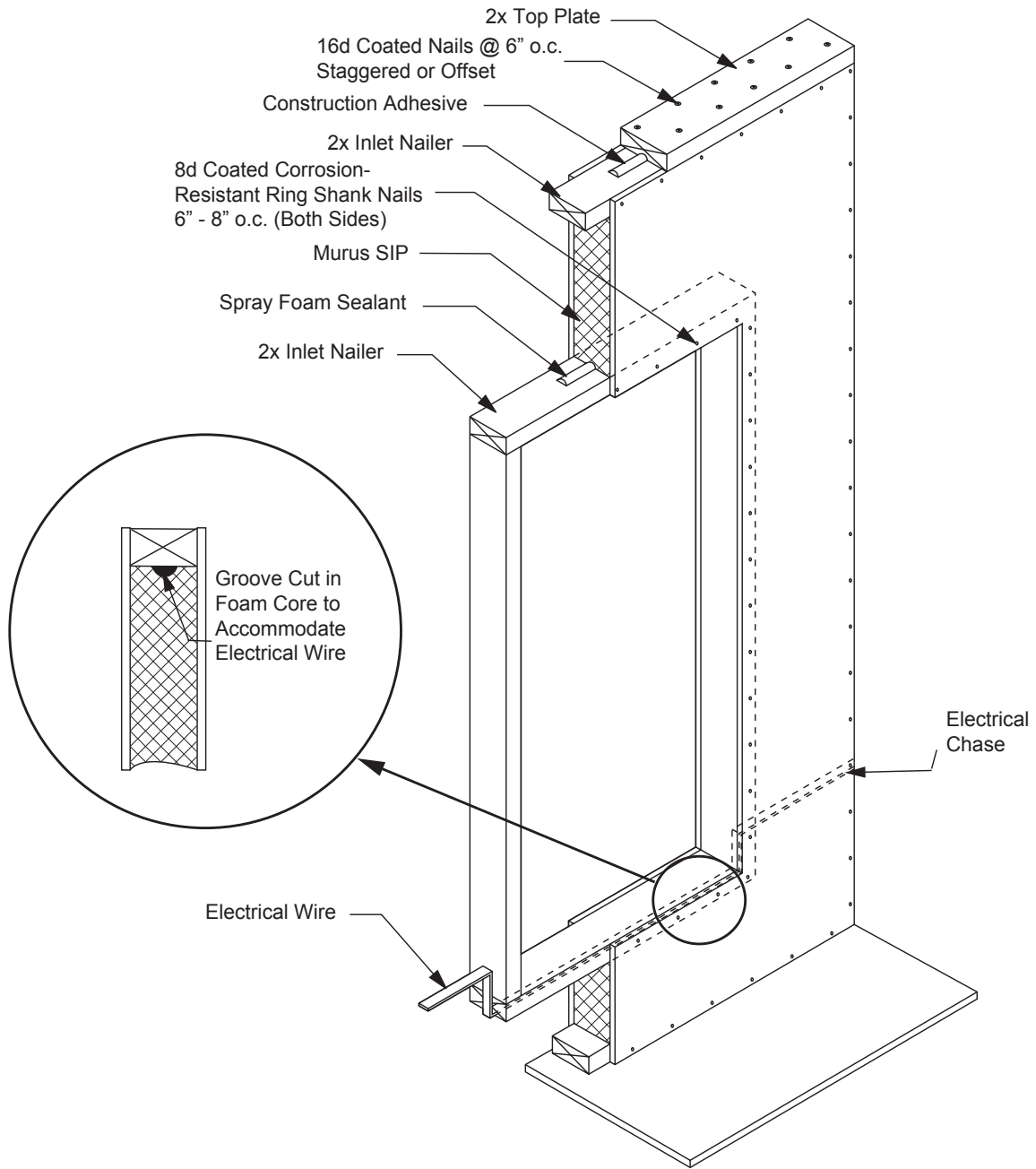

Figure 27. Typical Wiring Around Windows



FINISHING DETAILS

The following section provides some pertinent information about finishing a Murus SIP building. Obviously, not every situation can be covered so please consult with Murus if you have additional questions about finishing details.

Continuous Nailing Surface:

A significant advantage of SIP construction is that it provides a continuous nailing surface over the entire interior and exterior wall and roof surfaces. This makes it more convenient to hang drywall and kitchen cabinets, install interior partitions, roofing, siding, and trim.

Vapor Barriers:

With Murus SIPs, interior vapor barriers (such as 6 mil. poly film) are unnecessary unless required by local building codes. Unlike conventional 'stick frame' construction, properly installed and sealed Murus SIPs do not have wall cavities where water vapor can collect and condense. Further, the Murus Polyurethane core is a closed-cell foam which acts as a vapor barrier.

House Wraps:

A house wrap or building felt is to be applied to the exterior of the wall panels prior to installation of exterior finish materials. Selection of the material used should be based on the siding and/or exterior finish material being used, the recommendation of the siding manufacturer, and sound building practices. See **Siding and Exterior Finishes** on Page 55 for more information.

Air Infiltration:

It is Murus's intent and recommendation to eliminate as much air infiltration as possible through the use of Murus SIPs, the liberal use of spray foam sealant, construction adhesives, and caulk. Contrary to prior practices of "allowing a building to breathe", Murus recommends making it as "tight" as possible and installing an air-to-air exchanger.

Air Exchangers:

An air-to-air exchanger is a mechanical device that introduces fresh outside air and tempers and/or dehumidifies it with outgoing stale interior air, recovering much of the heat or energy from the interior air. There are two basic types of exchangers, the Heat Recovery Ventilator (HRV) and the Energy Recovery Ventilator (ERV). HRV units are best suited for colder northern climates because they transfer the heat energy from the warm moist air being exhausted to the cooler dry air being brought in. The transfer of energy pre-heats the incoming air and helps reduce heating costs. ERV units are best suited for warmer

southern climates because they reduce the humidity of the incoming air. The reduction of humidity helps reduce cooling costs. Consult with your mechanical contractor for what is best for your project.

IMPORTANT: An air-to-air exchanger is required to control indoor air pollutants, to maintain a healthy quality of air, and to remove excessive humidity that can cause serious harm to SIPs and to other parts of your home. Failure to install and operate a properly sized air exchanger can lead to excessive interior moisture levels, which can damage building components, cause wood decay, and propagate molds and mildews which contribute to poor indoor air quality, and may void the warranty on the panels. Please contact Murus or a qualified mechanical contractor for further information on air-to-air heat exchangers.

Sealing the Panel Seams:

IMPORTANT: It is recommended that the panel joints be sealed with a liberal amount of spray foam at the tongue-and-groove connection during panel installation.

The exterior seams between panels may be sealed once installation of the panels is complete. The panels are manufactured to create a foam-to-foam contact with a gap between OSB skins to allow for expansion of the OSB. It is recommended that a bead of spray foam sealant is to be applied into the gap between the OSB skins with the excess foam left intact until the exterior finish is being applied.

Drywall and Other Interior Finishes:

The most common interior wall surface is drywall. Murus recommends that drywall be applied directly to the panel surface perpendicular to the panel joints, using the drywall manufacturer's recommended fastening schedule and finishing details. This orientation will give the most strength to the drywall joints. If drywall must be installed parallel with the panel seams, be sure to offset the drywall seams from the panel seams by a minimum of 12". Standard installation practices can be used regarding piecing, joining and finishing.

Other materials used for the interior finish, such as tongue and groove boards, paneling, etc. may be applied using accepted practices.

Roofing:

Murus recommends the use of a lightweight felt product under the finished roofing materials. The product allows moisture to pass through its membrane while blocking the flow of rain water and/or condensed moisture. The covering also offers temporary protection of the roof surfaces and does not have to be removed before applying shingles. Finished roofing material can include heavyweight asphalt or composite shingles, metal, wood or slate. **NOTE:** Always install roofing materials according to accepted methods and in accordance with the manufacturer's recommendations.

Shingles:

Not all shingle manufacturers warrant shingles applied directly over an insulated deck or SIPs. Depending on your choice of manufacturer, an additional ventilated space may be required for warranty qualification. An additional ventilated space is recommended and is always more desirable. Venting may also increase the life of the shingle by lowering the shingle's temperature.

Venting the Roof:

The preferred and recommended method of roofing installation is on an elevated, ventilated surface (see Figure 28). Furring strips or strapping are screwed vertically over a layer of felt to the exterior surface of the roof panel on 16 to 24 inch centers. A layer of sheathing material is applied on the strapping as the nail base for the shingles. (For metal roof applications, an additional layer of strapping, installed horizontally, can be used in lieu of the sheathing.) This system requires both eave and ridge vents to vent the cavity and prevent condensation and heat buildup. For eave, soffit and fascia details, see Figure 17A through 17C on Pages 36 and 37.

NOTE: This method may help reduce the chance of shingle lifting, ridging and definition lines caused by frost and/or the presence of moisture.

Figure 28. Ventilated Roof System

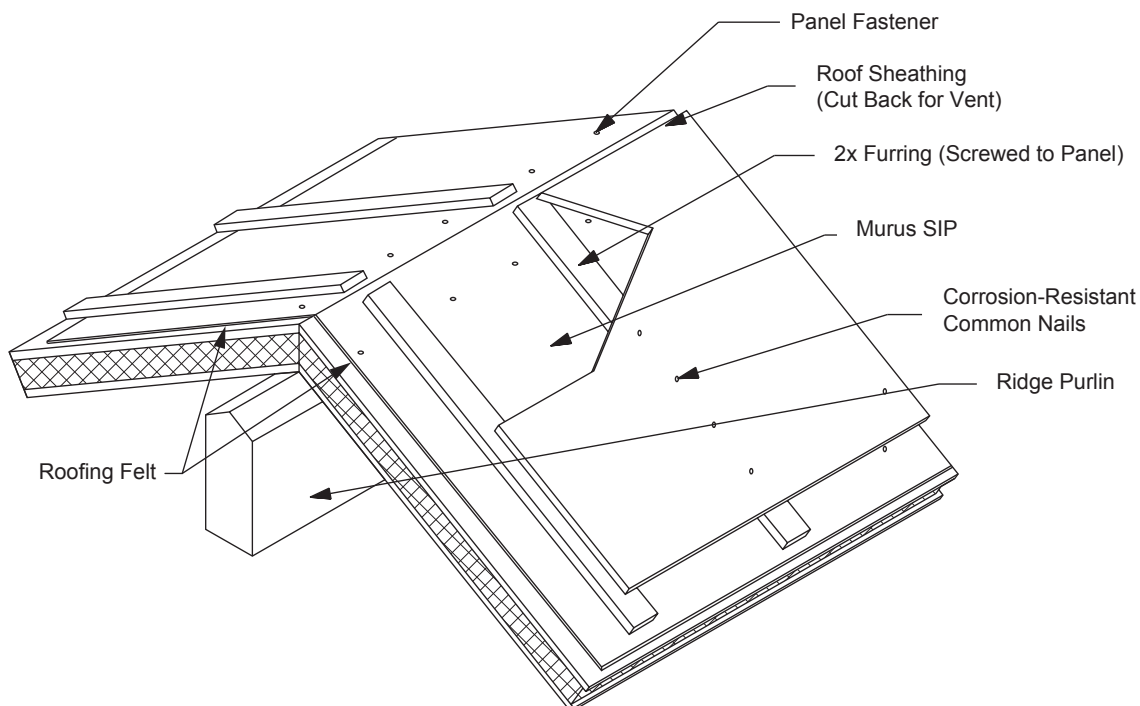

Siding and Exterior Finishes:

Virtually any type of siding may be applied to the exterior surface of a wall SIP. Some common materials include a variety of vinyl siding, aluminum siding, cementitious, and wood sidings to include clapboard, shiplap, board and batten, and shingles.

NOTE: All wood sidings are to be kiln dried. Green or air-dried sidings must be furred away from the panel surface, with a layer of house wrap or felt paper installed. Always follow acceptable building practices and/or manufacturer's installation instructions.

Sidings and trims are to be installed as a weatherproof covering to protect the SIPs from moisture and/or water damage. Exterior finishes should always be installed in accordance with the manufacturer's recommended installation instructions and/or acceptable building practices. When installing exterior finishes, it is required to first apply a layer of house wrap or felt paper over the SIPs to protect them from moisture and/or water damage. The use of flashing and waterproof membranes are recommended in water leak-prone areas for added protection.

NOTE: Slight inaccuracies in installation and improper sealing techniques, compounded by weathering of the exterior finishes, will eventually result in water leaks. Once a leak has developed, it generally does not become apparent until serious damage to the SIPs has occurred. Therefore, it is strongly recommended that inspections be done at regular intervals, and preventive maintenance be carried out on the exterior finishes to prevent any such damage to the SIPs.

Masonry Finishes:

Masonry and fiber-reinforced stuccos can also be used if a ventilated air space is provided. Ventilated air spaces allow these materials to breathe and expand and contract separately from the panel surface. Follow accepted building practices and the finish material manufacturer's recommendations for ventilation and proper installation.

Masonry materials such as brick veneer must not come in direct contact with the SIP. A vented air space between the veneer and SIPs, and weep holes in the masonry must be provided (see Figure 29, Page 57).

Figure 29. Veneer Detail

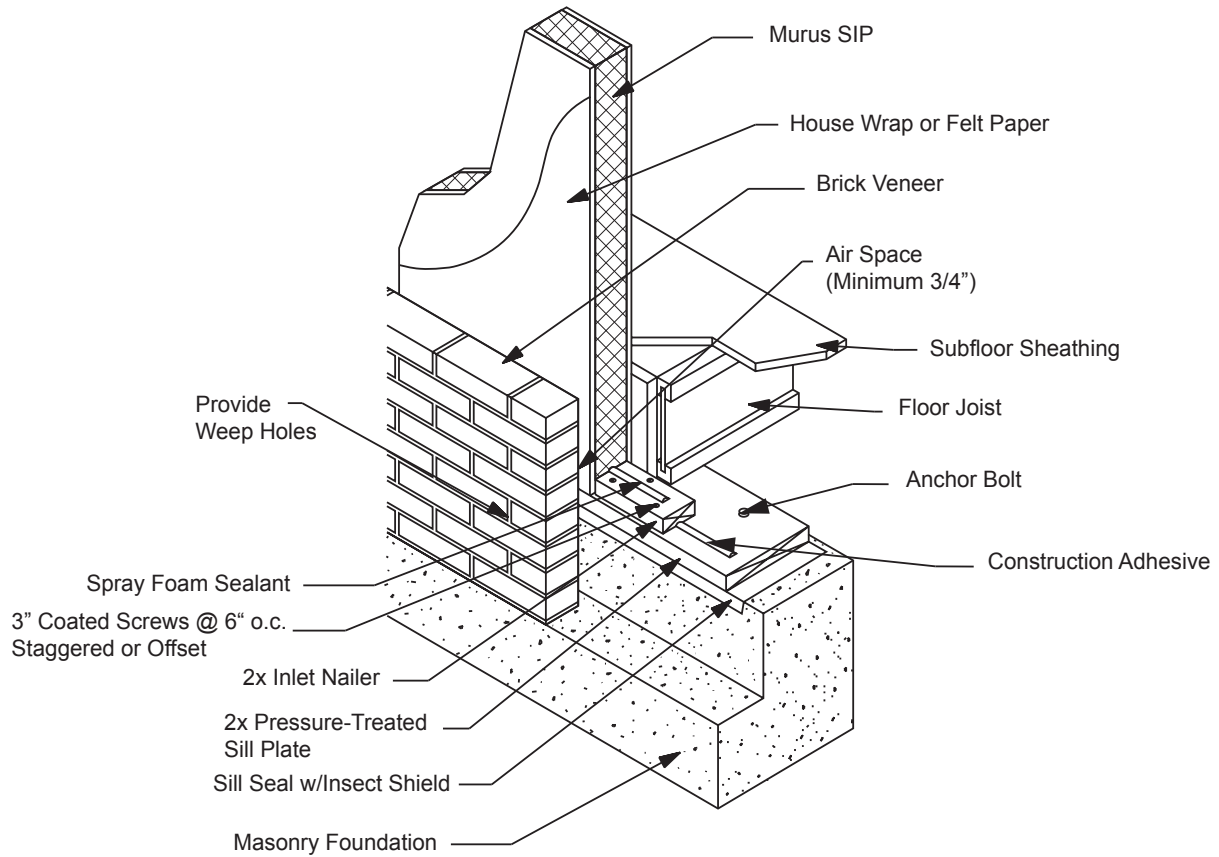

Interior Finish: Trim, Cabinets, Etc.:

Interior and exterior trim details are similar for SIP and conventional construction. The primary difference is that in SIP construction there is a continuous nailbase on all wall and/or ceiling surfaces. This facilitates the attachment of cabinets, trim, picture frames and other fixtures.

APPENDIX A

MURUS STRUCTURAL INSULATING PANEL TECHNICAL GLOSSARY

2X Plates and Nailers Nominal dimensional lumber (such as 2" x 4" nominal) used to frame corners, rough openings, eaves, rakes, sill plates, etc.

Axial Load A force of load acting in the direction of the object's axis.

Beam A component or building member used to transfer the loads of a floor or roof system to a vertical structural system such as a bearing wall or a set of posts.

Bearing Surface The part of the material able to support a structural load such as the top of a sill plate or the notched top of a post.

Cam-Lock A patented molded high density plastic device that is foamed in place in the Murus panel for the purpose of joining panels along their length.

Cam-Lock Wrench A small hand-held hex-head tool used to turn and lock cam-locks together.

Concrete Masonry Unit Analogous to a cinder block or a formed modular unit made of masonry used with mortar and other reinforcement to build walls and foundation systems.

Class "1" Foam An ASTM fire rating for foam core material. Also, the highest rating possible for combustible materials.

Crane A portable piece of machinery, usually attached to a truck with hydraulic controls, that is used to pick up and move heavy loads with cables attached to an extendable boom.

Dead Load The weight of the structural member and the weight of any permanent objects that act on that member.

Eave An overhang of the wall at the lower end of the roof.

Electrical Chase A one-inch cardboard tube that is foamed in place in the Murus wall panel for the purpose of running electric wires.

ERV Energy Recovery Ventilator.

EPS Expanded Polystyrene. Open cell rigid foam such as Styrofoam™.

Foam The rigid core of an insulating panel.

Foam Sealant See "Non-Expanding Foam".

Flexure A structural term analogous to bending that describes the action on a beam or structural system as a result of a transverse uniform or point load.

HRV Heat Recovery Ventilator.

ICC International Code Council, a membership association which develops the codes used to construct residential and commercial buildings, including homes and schools.

Isocyanate A liquid component of Murus urethane foam.

Level Horizontal. Perpendicular to vertical. Used as a building term to mean a member or surface is horizontally positioned.

Live Load A moving load such as snow or wind that acts on a structure.

NEOPOR® Registered trademark for charcoal-infused EPS manufactured by BASF. Charcoal infused EPS has a higher density and R-value per inch of thickness than standard “white” EPS.

Non-Expanding Foam A liquid urethane foam dispensed from a hand-held canister used to fill and seal expansion joints, gaps around doors, windows and skylights, and to create a bond between panel-to-panel and panel-to-wood surfaces.

O.C. On center.

OSB Oriented Strand Board. OSB consists of short wood strands that are layered and oriented perpendicular to each other, then bonded with adhesives for maximum strength, stiffness, and stability. Used as the interior and/or exterior sheathing surfaces of Murus SIPs.

OSHA Occupational Safety and Health Administration.

Panel Drawings A portion of the construction documents that show elevations, plans, and all necessary details that describe the building process for SIP construction.

Panel Fastener A corrosion-resistant nail or screw specially designed to fasten panels to a frame or to other panels.

Panel Router A hand-held power tool equipped with special bits to remove the foam core of SIPs for the purpose of inserting splines, inlets, and posts.

Plumb Vertical. Perpendicular to level. Used as a building term to mean that a surface or member is vertically positioned.

Polyol/Catalyst A liquid component of urethane foam.

Purlin A structural roof member oriented perpendicular to the pitch of the roof.

R-Value A measure of the capacity of a material, such as insulation, to resist heat flow, with increasing values indicating a greater capacity.

Racking A structural term to describe an in-plane shear action on a frame or diaphragm.

Rafter A structural roof member oriented parallel to the pitch of the roof.

Rake The overhang at the gable end of the roof.

Riser Wood or other material on which SIPs and other building materials are stacked. Risers create a space to allow a forklift, crane, etc. to pick up or set down materials. Risers also prevent these materials from coming in direct contact with the ground surface.

Sill A structural member used to cap a foundation such as the pressure treated sill plate. Also used to reference the bottom of a window or window rough opening.

SIP(s) Structural Insulating Panel(s).

Skin The outer rigid surface or material of a structural insulating panel.

Spline Usually a wood member used to join two panels together.

Spray Foam See “Non-Expanding Foam”.

Sticker See Riser.

Stress-Skin Panel A building product that uses strong, stiff exterior facing material around a less dense core to resist axial, flexural and racking loads. Includes structural insulating panels.

Truss A system of structural members oriented efficiently to carry building loads over open spans.

Urethane The rigid foam used in The Murus Company, Inc. PUR SIP. Also used in other forms in products such as mattresses, cushions, car bumpers, and high-grade insulating materials.

NOTES



The Murus Company, Inc.
PO Box 220 ■ 3234 Route 549
Mansfield, PA 16933
(800) 626-8787 ■ (570) 549-2100
Fax: (570) 549-2101
E-mail: info@murus.com ■ www.murus.com